



For more information, please contact your local ABB representative or visit

new.abb.com/drives
new.abb.com/drives/drivespartners
new.abb.com/motors-generators

Learn more from ACS380 website



Online manuals for the ACS380 drives



© Copyright 2025 ABB. All rights reserved.
Specifications subject to change without notice.

3AUA0000187460 REV F EN22.10.2025

LOW VOLTAGE AC DRIVES

ABB MACHINERY DRIVES

ACS380, 0.25 to 22 kW/0.37 to 30 hp



ENGINEERED TO OUTFIT

Reliable performance and ease of integration for machine builders. ACS380 machinery drives.

TABLE OF CONTENTS

04–05	The ACS380 machinery drives
06–07	Reliable performance and ease of integration for machine builders
08	Typical industries and applications
09	ACS380 drives software with versatile features
10–11	ACS380 – part of ABB’s all-compatible crane drives portfolio
12	Environmental product declarations
13	ABB AC drives comply with the EU Ecodesign requirements
14	Technical data
15	How to select a drive
16	Ordering information
17	Ratings, types and voltages
18	Dimensions
19–21	Construction variants
22	Control panel options and mounting kits
23	Door mounting and daisy chaining
24	Tools for configuration, monitoring and process tuning
25	Flexible connectivity to automation networks
26–27	Functional safety options
29	ABB drives and OPC UA
30	I/O option modules
31	Resistor braking
32	EMC – electromagnetic compatibility
33	Filters and chokes
34–35	Cooling, fuses and circuit breakers
37	ACS380 drives are compatible with the extensive ABB product offering
38	Choose the right motor for your application
39	Synchronous reluctance motors
40–41	Digital connectivity for drives and motors
42	Drive Composer 3 with ACS380
44	ABB Motion Services
45	A lifetime of peak performance

THE ACS380 MACHINERY DRIVES

Reliable performance and ease of integration

Thanks to its reliable performance and ease of integration, the ACS380 is an all-compatible machinery drive ideal for machine building. All-compatible ABB drives share the same architecture and user interface for ease of use.

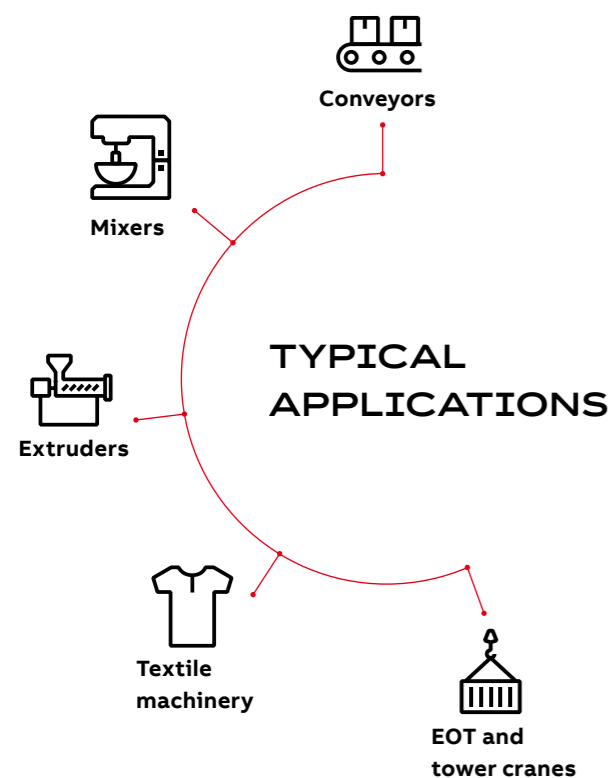

Excellent motor control

The ACS380 machinery drive is a robust and compact drive ideal for machine building. It can control various motor types from 0.25 to 22 kW. Whether the requirement is high starting torque, accurate speed control, stable torque or dynamic response to sudden load variations, the ACS380 drive meets it with or without encoder feedback.

Ease of integration

The ACS380 drive has many advanced features built-in as standard. A selection of variants and options allow the drive to be optimized for various fieldbus communication, I/O and EMC requirements. With the integrated functional safety features, the ACS380 drive can also be part of the machine's safety system via PROFIsafe over PROFINET and safely stop the motor when required. All together, this saves a lot of time and money for machine builders using large numbers of drives per year.

Designed to last 10 years or more

The design lifetime expectancy of the ACS380 drive and its overall components exceeds 10 years in normal operating environments. In some cases, ACS380 drive can last 20 years or more. Design features including coated circuit boards, minimized airflow through the electronics, and up to 50 °C operating temperature without derating make the ACS380 a safe choice for customers expecting high reliability. This is further enhanced by a full load test that is carried out on every single drive during production.



RELIABLE PERFORMANCE AND EASE OF INTEGRATION FOR MACHINE BUILDERS

The ACS380 machinery drives are part of ABB's all-compatible drives portfolio. The drives give you consistent performance throughout their whole life cycle. They also offer a wider range of standard and optional features for optimal machine building.

A perfect match for a wide range of machines

ACS380 drives are available in two variants. The standard variant meets the most typical machinery requirements, whereas the configured variant can be optimized for more specific needs.

Excellent motor control

ACS380 drives support various motor types including induction, permanent magnet and synchronous reluctance motors. Motor control performance with 3-phase current measurement meets demanding load profile requirements. In addition, ACS380 controls induction or permanent magnet motors with or without speed feedback from an encoder.



Ease of integration

An extensive selection of fieldbus modules enables connectivity with all major industrial automation networks. Communication of the ACS380 drive is automatically set at power-up for easy access from a PLC to the drive. Additional analog and digital I/O, or speed feedback can be added with option modules when needed.



Built-in functional safety

Safe Torque Off (STO) is a standard feature in all ACS380 drives. STO or Safe Stop 1 (SS1-t) can also be controlled via PROFIsafe or via CIP Safety with an optional communication module.



Ease of use

The ACS380 drive has an integrated control panel with a display and control keys. The control panel's icon-based menu helps in setting up the drive quickly and effectively. Also, external user panels are available for installation to a cabinet door or for operation via a Bluetooth connection.

All-compatible user interface

ACS380 is part of ABB all-compatible drives portfolio. Other products in this portfolio are ACS480, ACS580 and ACS880 drives. All these drives have the same, easy to use PC tools and similar intuitive multilingual user interface as well as parameter and function structure, making using and learning them fast and easy.



Drive based programmability

Adaptive programming allows customization of the drive software using sequential and function block programming. This is a standard feature of the ACS380 drive requiring no additional downloads or licenses. It may allow the reduction of system costs by replacing the need for a PLC.

Designed to last 10 years or more

The ACS380 drives have improved durability and reliability in harsh conditions, including coated circuit boards and minimized air flow through the electronics. The drives are designed for an ambient temperature of up to 50 °C without derating. Also, the foil coated control panel offers good protection against dust and moisture, and the galvanically isolated fieldbus gives noise immunity.

TYPICAL INDUSTRIES AND APPLICATIONS

ACS380 drives improve process performance, increase productivity, reduce external components, and ensure machine and personnel safety



01



02



03







04



05

- 01 Food and beverage
- 02 Material handling
- 03 Textile
- 04 Plastics
- 05 Lumber and wood

Industry	Application	Customer benefits
 Food and beverage	Mixers, conveyors, mills, compressors, blowers, fans, pumps, dryers, ovens, extruders	<ul style="list-style-type: none"> • Precise speed control guarantees food production quality in different conditions • Robust design to maximize machine lifetime • Safe Torque Off (SIL 3/PL e) function ensures machine and personnel safety • Product flexibility to meet requirements of different food production machines
 Material handling	Conveyors Cranes, including: Indoor EOT cranes (hoist, trolley, and long travel) and Construction/Tower cranes (hoist, trolley, and slew)	<ul style="list-style-type: none"> • High starting torque for demanding operation and movements • Soft acceleration and deceleration with S-curve speed ramp, reducing the stress on the mechanical parts • Crane compatible mechanical brake control logic built in, including other crane application features • Integrated brake chopper enabling faster and accurate stop and reversing cycles • Safe Torque Off (SIL 3) function to prevent unexpected movements (POUS) • BOX format (IP20): ideal fit for small crane cabinets, ensuring space-efficient integration and simplified installation • +N5050 Antisway crane control for smooth, safe motion and automatic load-sway reduction, improving handling precision and travel performance (trolley/long travel) on indoor EOT cranes
 Textile	Conveyors, drum washers, dyeing machines, spinning, pumps	<ul style="list-style-type: none"> • Precise and adjustable speed and torque control for highly accurate stretching management and better quality of the end product • Coated circuit boards, 50 °C ambient without derating and minimized air flow through electronics for reliable operation in harsh environments • Undervoltage control ensures uninterrupted production during power network disturbance
 Plastics	Extruders, molding machines, hoppers, polishers	<ul style="list-style-type: none"> • Accurate speed control to enable a steady extrusion process • Smooth speed profile to prevent plastic film web breakages • The scalable all-compatible platform allows easy process and component optimization with different drive types that share the same user interface and tools
 Lumber and wood	Conveyors, sorting lines, sanding, cutting	<ul style="list-style-type: none"> • High starting torque for demanding operation and movements • Soft acceleration and deceleration with S-curve speed ramp, reducing the stress on the mechanical parts • Mechanical brake control logic built in • Integrated brake chopper enabling faster and accurate stop and reversing cycles • Safe Torque Off (SIL 3) function to prevent unexpected movements

ACS380 DRIVES SOFTWARE WITH VERSATILE FEATURES

Excellent motor control. Whether the requirement is high starting torque, accurate speed control, stable torque or dynamic response to sudden load variations, ACS380 meets it with or without encoder feedback.

One drive for different motor types. ACS380 perfectly supports induction, permanent magnet and synchronous reluctance motors.

Easy integration to automation. Preconfigured fieldbus protocols enable connectivity with all major industrial automation networks with minimal effort and complexity.

Adaptive programming provides extra flexibility by offering easy alternative for simple programming needs. Download Drive Composer entry for free to start writing your application.

Built-in features for precise movements. Speed or torque reference can easily be adjusted for various needs. Movement range can be controlled with limit switches, and motor stopped in an optimal way with integrated braking chopper and mechanical brake control logic.

Load profile feature collects drive values, such as current and stores them in a log. This enables you to analyze and optimize the application with the help of historical data load.

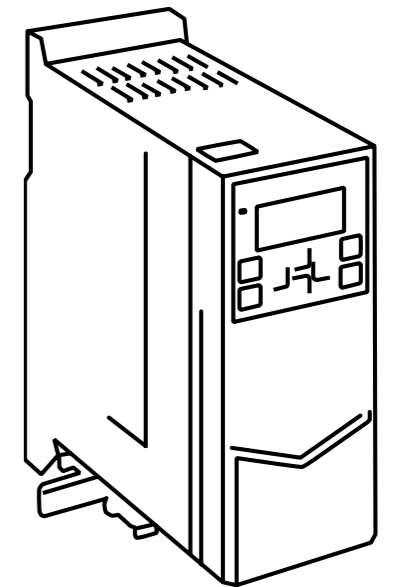



ACS380 – PART OF ABB’S ALL-COMPATIBLE CRANE DRIVES PORTFOLIO

Designed to move your overhead and tower cranes reliably day after day.

All built-in for efficient overhead and tower crane movements

The drive includes built-in control for hoist, trolley and long travel/slew movements and the essential functions for typical crane applications. It works precisely both in open and closed loop configurations, and includes sensorless antisway for indoor crane travel movements.

Reliable operation

With their coated circuit boards, 50 °C ambient rating and advanced cooling system, ACS380 drives are made to last even in demanding environments.

A lot packed into a compact unit

The drive includes an integrated brake chopper for dynamic braking and safe torque off (SIL 3) as standard. The drive can be installed in a crane cabinet either to a DIN rail or with a screw installation.

Why select ABB’s all-compatible crane drives?

- The ACS380 and ACS880 drives give the same user experience
- Possibility to use same assistant control panel or PC tool
- Adaptive block programming for extended crane functionality

Works with following crane interfaces

- Joystick
- Pendant controller
- Motor potentiometer
- Fieldbus control

Built-in crane application includes

- Slowdown logic
- End limit logic
- Fast stop function
- Mechanical brake control
- Adaptive programming based sensorless antisway for indoor cranes

ACS380 supports the optional +N5050 Anti-sway Crane Control firmware, enabling automatic load-sway reduction, improved handling precision, and enhanced travel performance for trolley and long-travel motions on indoor EOT cranes.

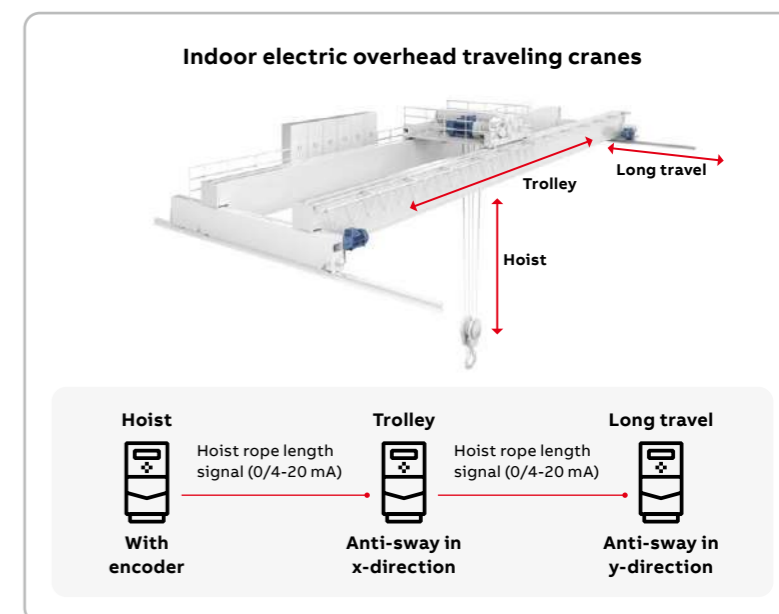
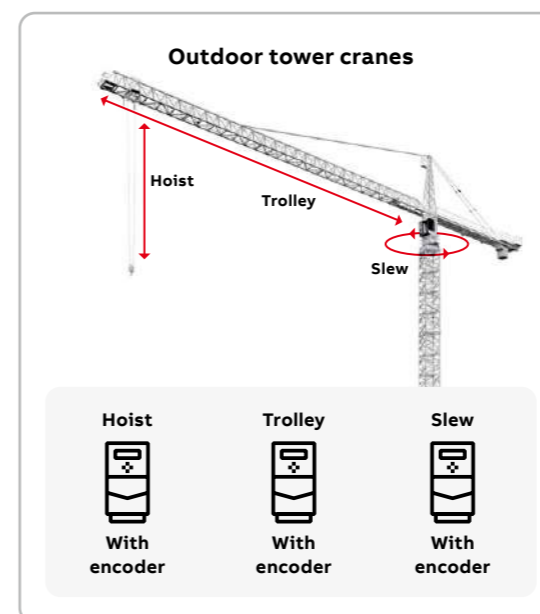



As part of ABB’s sustainability strategy, the company will provide Environmental Product Declarations for relevant products, contributing to transparent and environmentally conscious business practices.

Environmental Product Declarations (EPDs) are standardized, third party verified, documents that provide information about the environmental performance of a product throughout its life cycle. They are based on Life Cycle Assessment (LCA) data and provide information on a range of environmental impacts such as carbon footprint, energy consumption, and resource use. EPDs are part of ABB’s commitment to transparency and environmental sustainability.

ABB Drives EPDs include:

1. Raw materials extraction and processing: Information about the materials used in the product.
2. Manufacturing process: Details about the manufacturing process, energy consumption, and emissions during production.
3. Transportation: Information on the transportation of raw materials to the manufacturing site, and the transportation of the finished product to the end-user.
4. Installation: Environmental impacts associated with the installation process, including energy use and emissions.
5. Use phase: Energy consumption during the operation of the frequency converter based on efficiency its rating.

6. Maintenance: Information about the environmental impact of maintaining and servicing the frequency converter during its operational life.
7. End of life: Details about the recyclability of the product and the environmental impact of its disposal.

Environmental impact categories:

EPDs include information on a range of environmental impact categories, such as global warming potential, ozone depletion, acidification, eutrophication, and others.

Declaration of Global Warming Potential (GWP):

Information about the product’s contribution to climate change, expressed in terms of carbon dioxide equivalent (CO₂-eq).

ABB Group EPDs follow the ISO 14025 standard.

The ABB EPD’s can be found here: [Environmental Product Declarations – ABB Group \(global.abb\)](https://www.abb.com/global/epd)



ABB AC DRIVES COMPLY WITH THE EU ECODESIGN REQUIREMENTS

The Ecodesign regulation (EU) 2019/1781 is the legislative framework that sets minimum energy efficiency requirements for low voltage induction motors and variable speed drives. AC drives and power drive systems are classified according to their power losses. From July 2021, the minimum requirement for non-regenerative AC drives in EU is IE2.

ABB’s AC drives (machinery, general, industrial and industrial specific drives) comply with the strictest requirements of the standard for energy efficiency and are classified as IE2.

Energy efficiency classes for a Complete Drive Module (CDM)

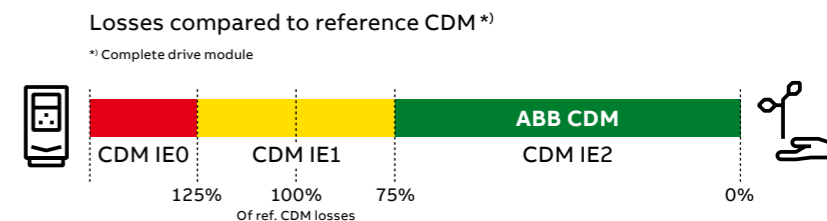

Markings on the ABB LV AC drives

Unique identifier QR code for Ecodesign information



IE class and % loss of rated apparent power 50 Hz, 400 V

IE2 (90;100) 2.3 %

Unique QR codes are located on the rating plate and/or the front of the drive.

Web-based ABB EcoDesign Tool



- Calculates absolute and relative losses and efficiency data at standard and user-defined operating points according to EU regulation 2019/1781 for complete drive module (CDM), LV motors with VSD supply, and power drive system (PDS)
- Losses and efficiency data at operating points in graphical and table format
- Printable efficiency report with possibility to customize title and additional details
- Report can be converted to PDF or CSV format and shared via email

The regulation was implemented in two steps:

Step 1: July 1, 2021

- Power range: from 0.12 to 1000 kW
- 3-phase LV AC drives with diode rectifier
- Drive manufacturers must declare power losses as a percentage of the rated apparent output power at 8 different operating points, as well as standby losses. The international IE level is given at the nominal point. Drives fulfilling the requirements are CE-marked.

Out of scope of the regulation:

- All drives without CE marking
- The following low voltage AC drives: regenerative drives, low-harmonic drives (THD < 10%), multiple AC-output drives and single-phase drives.
- Medium-voltage drives, DC drives and traction drives
- Drive cabinets that already have conformity-assessed modules

Step 2: July 1, 2023

No changes for AC drives

For more information, see: ecodesign.drivesmotors.abb.com

TECHNICAL DATA

Mains connection	
Voltage and power range	1-phase, 200 to 240 V, +10%/-15% 0.25 to 3.0 kW (1/3 to 3 HP) 3-phase, 200 to 240 V, +10%/-15% 0.25 to 15 kW (1/3 to 20 HP) 3-phase, 380 to 480 V, +10%/-15% 0.37 to 22 kW (1/2 to 30 HP)
Frequency	50/60 Hz ± 5%
Efficiency class (IEC 61800-9-2)	IE2
Common DC connection	
DC voltage level	-1 and -2 types 270 to 324 V ±10% -4 types 513 to 648 V ±10%
Charging circuit	Internal charging circuit
Motor connection	
Voltage	0 to U_N , 3-phase
Frequency	0 to 599 Hz
Motor control	Scalar control Vector control
Switching frequency	1 to 12 kHz, default 4 kHz
Dynamic braking	Flux braking (moderate or full) Resistor braking (optional)
Motor control performance	
Speed control performance, open loop	
Static accuracy	20% of motor rated slip
Dynamic accuracy	1% seconds with 100% torque step
Speed control performance, closed loop	
Static accuracy	0.1% of motor rated speed
Dynamic accuracy	<1% seconds with 100% torque step
Torque control performance	
Torque step rise time	< 10 ms, rated torque step
Non-linearity	±5% with rated torque
Braking power connection	
Brake chopper	Built-in brake chopper as standard
Brake resistor	External resistor connected to drive
Functional safety	
Built-in safety features	Safe Torque Off (STO) EN/IEC61800-5-2: IEC61508 ed2: SIL 3, IEC 61511: SIL 3, IEC 62061: SIL CL 3, EN ISO 13849-1: PL e/cat. 3

Environmental limits	
Ambient temperature	
Transportation and storage	-40 to +70 °C (-40 to +158 °F)
Operation	-10 to +50 °C (14 to 122 °F), with derating up to 60 °C (except R0, which has max. temperature of 50 °C)
Cooling method	Air-cooled, dry clean air
Altitude	0 to 4000 m, (0 to 13000 ft) for 400 V units (see allowed power systems in HW manual) 0 to 2000 m, (0 to 6600 ft) for 200 V units derating above 1000 m (3300 ft)
Relative humidity	5 to 95%, no condensation allowed
Degree of protection	IP20 as standard Optional UL type 1 Kit
Contamination levels	No conductive dust allowed
Storage	IEC 60721-3-1, Class 1C2 (chemical gases) Class 1S2 (solid particles)
Transportation	IEC 60721-3-2, Class 2C2 (chemical gases) Class 2S2 (solid particles)
Operation	IEC 60721-3-3, Class 3C2 (chemical gases) Class 3S2 (solid particles)
Product compliance	
	CE Low Voltage Directive 2014/35/EU 2, EN 61800-5-1: 2007 Machinery Directive 2006/42/EC, EN 61800-5-2: 2007 EMC Directive 2014/30/EU, EN 61800-3: 2004 + A1: 2012 UL, cUL certification – file E211945 TUV Certification for functional safety Quality assurance system ISO 9001 Ecodesign (EU) 2019/1781 Environmental system ISO 14001 Waste electrical and electronic equipment directive (WEEE) 2002/96/EC RoHS directive 2011/65/EU EAC, KC, RCM

HOW TO SELECT A DRIVE

How you build up your ordering code

Start by identifying your supply voltage
This indicates what rating table to use;
see page 17.

Select the ordering code for the ACS380
machinery drive by choosing either the
standard or the configured variant (page
16). Then choose the desired EMC level on
page 6. If the configured variant is
selected, choose the desired fieldbus
protocol (page 30) by selecting the correct
option code and add the option codes to
the drive's ordering code.

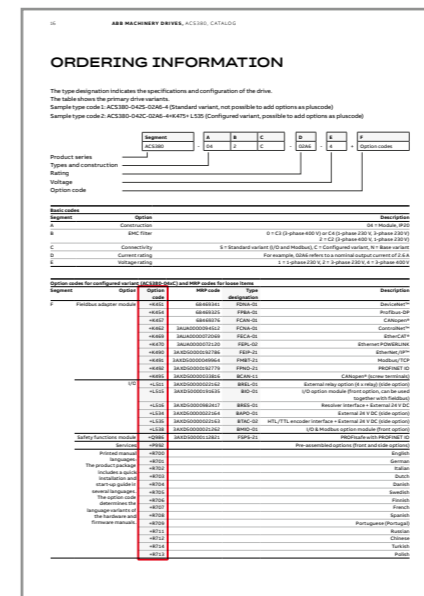

Page 16

Choose other options (on page 30) and
add the option codes to the drive's order
code. Remember to use a "+" mark before
each option code.

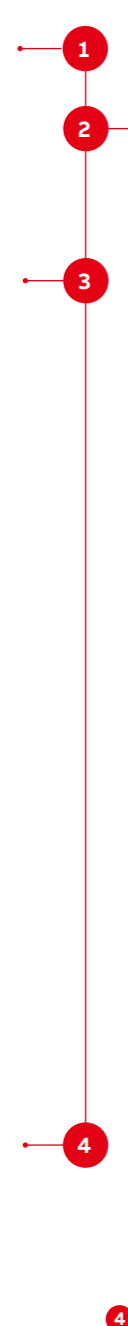
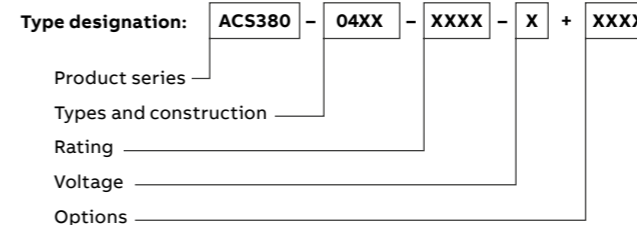

Choose the motor power and
current rating from the ratings
table on page 17.

RATINGS, TYPES AND VOLTAGES									
Table 1. 200 V range (200 to 240 V). The power ratings are valid at nominal voltage 200 V (0.8 to 0.85 PF).									
Motor type	Power (kW)	Current (A)	Speed (rpm)	Light duty (min)	Heavy duty (min)	Very heavy duty (min)	Max. output current (A)	Max. output torque (Nm)	Max. output power (kW)
ACS380-0400-01	0.25	1.2	1420	1.5	1.5	1.5	1.2	1.5	0.25
ACS380-0400-02	0.37	1.7	1420	1.5	1.5	1.5	1.7	2.2	0.37
ACS380-0400-03	0.55	2.5	1420	1.5	1.5	1.5	2.5	3.7	0.55
ACS380-0400-04	0.75	3.5	1420	1.5	1.5	1.5	3.5	5.2	0.75
ACS380-0400-05	1.1	5.0	1420	1.5	1.5	1.5	5.0	7.5	1.1
ACS380-0400-06	1.5	7.0	1420	1.5	1.5	1.5	7.0	10.5	1.5
ACS380-0400-07	2.2	10.0	1420	1.5	1.5	1.5	10.0	15.0	2.2
ACS380-0400-08	3.0	14.0	1420	1.5	1.5	1.5	14.0	20.0	3.0
ACS380-0400-09	4.0	18.0	1420	1.5	1.5	1.5	18.0	26.0	4.0
ACS380-0400-10	5.5	25.0	1420	1.5	1.5	1.5	25.0	35.0	5.5
ACS380-0400-11	7.5	35.0	1420	1.5	1.5	1.5	35.0	48.0	7.5
ACS380-0400-12	10.0	45.0	1420	1.5	1.5	1.5	45.0	63.0	10.0
ACS380-0400-13	15.0	70.0	1420	1.5	1.5	1.5	70.0	95.0	15.0
ACS380-0400-14	20.0	90.0	1420	1.5	1.5	1.5	90.0	125.0	20.0
ACS380-0400-15	25.0	110.0	1420	1.5	1.5	1.5	110.0	155.0	25.0
ACS380-0400-16	30.0	130.0	1420	1.5	1.5	1.5	130.0	185.0	30.0
ACS380-0400-17	40.0	170.0	1420	1.5	1.5	1.5	170.0	245.0	40.0
ACS380-0400-18	55.0	230.0	1420	1.5	1.5	1.5	230.0	330.0	55.0
ACS380-0400-19	75.0	310.0	1420	1.5	1.5	1.5	310.0	440.0	75.0
ACS380-0400-20	100.0	400.0	1420	1.5	1.5	1.5	400.0	580.0	100.0
ACS380-0400-21	150.0	600.0	1420	1.5	1.5	1.5	600.0	870.0	150.0
ACS380-0400-22	200.0	800.0	1420	1.5	1.5	1.5	800.0	1160.0	200.0
ACS380-0400-23	250.0	1000.0	1420	1.5	1.5	1.5	1000.0	1450.0	250.0
ACS380-0400-24	300.0	1200.0	1420	1.5	1.5	1.5	1200.0	1740.0	300.0
ACS380-0400-25	400.0	1600.0	1420	1.5	1.5	1.5	1600.0	2310.0	400.0
ACS380-0400-26	550.0	2200.0	1420	1.5	1.5	1.5	2200.0	3100.0	550.0
ACS380-0400-27	750.0	3000.0	1420	1.5	1.5	1.5	3000.0	4150.0	750.0
ACS380-0400-28	1000.0	4000.0	1420	1.5	1.5	1.5	4000.0	5500.0	1000.0
ACS380-0400-29	1500.0	6000.0	1420	1.5	1.5	1.5	6000.0	8250.0	1500.0
ACS380-0400-30	2000.0	8000.0	1420	1.5	1.5	1.5	8000.0	11000.0	2000.0
ACS380-0400-31	2500.0	10000.0	1420	1.5	1.5	1.5	10000.0	13750.0	2500.0
ACS380-0400-32	3000.0	12000.0	1420	1.5	1.5	1.5	12000.0	16500.0	3000.0
ACS380-0400-33	4000.0	16000.0	1420	1.5	1.5	1.5	16000.0	22000.0	4000.0
ACS380-0400-34	5500.0	22000.0	1420	1.5	1.5	1.5	22000.0	29750.0	5500.0
ACS380-0400-35	7500.0	30000.0	1420	1.5	1.5	1.5	30000.0	40500.0	7500.0
ACS380-0400-36	10000.0	40000.0	1420	1.5	1.5	1.5	40000.0	54000.0	10000.0
ACS380-0400-37	15000.0	60000.0	1420	1.5	1.5	1.5	60000.0	81000.0	15000.0
ACS380-0400-38	20000.0	80000.0	1420	1.5	1.5	1.5	80000.0	108000.0	20000.0
ACS380-0400-39	25000.0	100000.0	1420	1.5	1.5	1.5	100000.0	135000.0	25000.0
ACS380-0400-40	30000.0	120000.0	1420	1.5	1.5	1.5	120000.0	162000.0	30000.0
ACS380-0400-41	40000.0	160000.0	1420	1.5	1.5	1.5	160000.0	216000.0	40000.0
ACS380-0400-42	55000.0	220000.0	1420	1.5	1.5	1.5	220000.0	292500.0	55000.0
ACS380-0400-43	75000.0	300000.0	1420	1.5	1.5	1.5	300000.0	405000.0	75000.0
ACS380-0400-44	100000.0	400000.0	1420	1.5	1.5	1.5	400000.0	540000.0	100000.0
ACS380-0400-45	150000.0	600000.0	1420	1.5	1.5	1.5	600000.0	810000.0	150000.0
ACS380-0400-46	200000.0	800000.0	1420	1.5	1.5	1.5	800000.0	1080000.0	200000.0
ACS380-0400-47	250000.0	1000000.0	1420	1.5	1.5	1.5	1000000.0	1350000.0	250000.0
ACS380-0400-48	300000.0	1200000.0	1420	1.5	1.5	1.5	1200000.0	1620000.0	300000.0
ACS380-0400-49	400000.0	1600000.0	1420	1.5	1.5	1.5	1600000.0	2160000.0	400000.0
ACS380-0400-50	550000.0	2200000.0	1420	1.5	1.5	1.5	2200000.0	2925000.0	550000.0
ACS380-0400-51	750000.0	3000000.0	1420	1.5	1.5	1.5	3000000.0	4050000.0	750000.0
ACS380-0400-52	1000000.0	4000000.0	1420	1.5	1.5	1.5	4000000.0	5400000.0	1000000.0
ACS380-0400-53	1500000.0	6000000.0	1420	1.5	1.5	1.5	6000000.0	8100000.0	1500000.0
ACS380-0400-54	2000000.0	8000000.0	1420	1.5	1.5	1.5	8000000.0	10800000.0	2000000.0
ACS380-0400-55	2500000.0	10000000.0	1420	1.5	1.5	1.5	10000000.0	13500000.0	2500000.0
ACS380-0400-56	3000000.0	12000000.0	1420	1.5	1.5	1.5	12000000.0	16200000.0	3000000.0
ACS380-0400-57	4000000.0	16000000.0	1420	1.5	1.5	1.5	16000000.0	21600000.0	4000000.0
ACS380-0400-58	5500000.0	22000000.0	1420	1.5	1.5	1.5	22000000.0	29250000.0	5500000.0
ACS380-0400-59	7500000.0	30000000.0	1420	1.5	1.5	1.5	30000000.0	40500000.0	7500000.0
ACS380-0400-60	10000000.0	40000000.0	1420	1.5	1.5	1.5	40000000.0	54000000.0	10000000.0
ACS380-0400-61	15000000.0	60000000.0	1420	1.5	1.5	1.5	60000000.0	81000000.0	15000000.0
ACS380-0400-62	20000000.0	80000000.0	1420	1.5	1.5	1.5	80000000.0	108000000.0	20000000.0
ACS380-0400-63	25000000.0	100000000.0	1420	1.5	1.5	1.5	100000000.0	135000000.0	25000000.0
ACS380-0400-64	30000000.0	120000000.0	1420	1.5	1.5	1.5	120000000.0	162000000.0	30000000.0
ACS380-0400-65	40000000.0	160000000.0	1420	1.5	1.5	1.5	160000000.0	216000000.0	40000000.0
ACS380-0400-66	55000000.0	220000000.0	1420	1.5	1.5	1.5	220000000.0	292500000.0	55000000.0
ACS380-0400-67	75000000.0	300000000.0	1420	1.5	1.5	1.5	300000000.0	405000000.0	75000000.0
ACS380-0400-68	100000000.0	400000000.0	1420	1.5	1.5	1.5	400000000.0	540000000.0	100000000.0
ACS380-0400-69	150000000.0	600000000.0	1420	1.5	1.5	1.5	600000000.0	810000000.0	150000000.0
ACS380-0400-70	200000000.0	800000000.0	1420	1.5	1.5	1.5	800000000.0	1080000000.0	200000000.0
ACS380-0400-71	250000000.0	1000000000.0	1420	1.5	1.5	1.5	1000000000.0	1350000000.0	250000000.0
ACS380-0400-72	300000000.0	1200000000.0	1420	1.5	1.5	1.5	1200000000.0	1620000000.0	300000000.0
ACS380-0400-73	400000000.0	1600000000.0	1420	1.5	1.5	1.5	1600000000.0	2160000000.0	400000000.0
ACS380-0400-74	550000000.0	2200000000.0	1420	1.5	1.5	1.5	2200000000.0	2925000000.0	550000000.0
ACS380-0400-75	750000000.0	3000000000.0	1420	1.5	1.5	1.5	3000000000.0	4050000000.0	750000000.0
ACS380-0400-76	1000000000.0	4000000000.0	1420	1.5	1.5	1.5	4000000000.0	5400000000.0	1000000000.0
ACS380-0400-77	1500000000.0	6000000000.0	1420	1.5	1.5	1.5	6000000000.0	8100000000.0	1500000000.0
ACS380-0400-78	2000000000.0	8000000000.0	1420	1.5	1.5	1.5	8000000000.0	10800000000.0	2000000000.0
ACS380-0400-79	2500000000.0	10000000000.0	1420	1.5	1.5	1.5	10000000000.0	13500000000.0	2500000000.0
ACS380-0400-80	3000000000.0	12000000000.0	1420	1.5	1.5	1.5	12000000000.0	16200000000.0	3000000000.0
ACS380-0400-81	4000000000.0	16000000000.0	1420	1.5	1.5	1.5	16000000000.0	21600000000.0	4000000000.0
ACS380-0400-82	5500000000.0	22000000000.0	1420	1.5	1.5	1.5	22000000000.0		

ORDERING INFORMATION

The type designation indicates the specifications and configuration of the drive.

The table shows the primary drive variants.

Sample type code 1: ACS380-042S-02A6-4 (Standard variant, not possible to add options as pluscode)

Sample type code 2: ACS380-042C-02A6-4+K475+ L535 (Configured variant, possible to add options as pluscode)

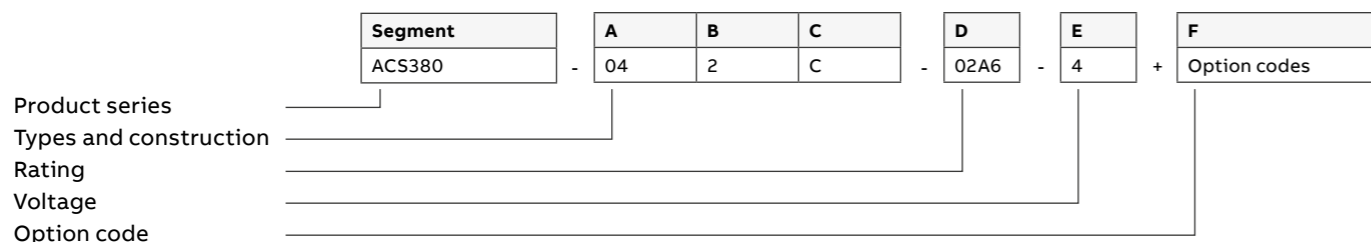

Basic codes		
Segment	Option	Description
A	Construction	04 = Module, IP20
B	EMC filter	0 = C3 (3-phase 400 V) or C4 (1-phase 230 V, 3-phase 230 V) 2 = C2 (3-phase 400 V, 1-phase 230 V)
C	Connectivity	S = Standard variant (I/O and Modbus), C = Configured variant, N = Base variant
D	Current rating	For example, 02A6 refers to a nominal output current of 2.6 A
E	Voltage rating	1 = 1-phase 230 V, 2 = 3-phase 230 V, 4 = 3-phase 400 V

Option codes for configured variant (ACS380-04xC) and MRP codes for loose items							
Segment	Option	Option code	MRP code	Type designation	Description		
F	Fieldbus adapter module	+K451	68469341	FDNA-01	DeviceNet™		
		+K454	68469325	FPBA-01	Profibus-DP		
		+K457	68469376	FCAN-01	CANopen®		
		+K462	3AUA0000094512	FCNA-01	ControlNet™		
		+K469	3AUA0000072069	FECA-01	EtherCAT®		
		+K470	3AUA0000072120	FEPL-02	Ethernet POWERLINK		
		+K490	3AXD50000192786	FEIP-21	EtherNet/IP™		
		+K491	3AXD50000049964	FMBT-21	Modbus/TCP		
		+K492	3AXD50000192779	FPNO-21	PROFINET IO		
		+K495	3AXD50000033816	BCAN-11	CANopen® (screw terminals)		
		I/O		+L511	3AXD50000022162	BREL-01	External relay option (4 x relay) (side option)
				+L515	3AXD50000191635	BIO-01	I/O option module (front option, can be used together with fieldbus)
				+L516	3AXD50000982417	BRES-01	Resolver interface + External 24 V DC
				+L534	3AXD50000022164	BAPO-01	External 24 V DC (side option)
+L535	3AXD50000022163			BTAC-02	HTL/TTL encoder interface + External 24 V DC (side option)		
Safety functions module		+L538	3AXD50000021262	BMIO-01	I/O & Modbus option module (front option)		
		+Q986	3AXD50000112821	FSPS-21	PROFIsafe with PROFINET IO		
		Services	+P992			Pre-assembled options (front and side options)	
		The product package includes a quick installation and start-up guide in several languages. The option code determines the language variants of the hardware and firmware manuals.		+R700			English
				+R701			German
				+R702			Italian
				+R703			Dutch
				+R704			Danish
				+R705			Swedish
				+R706			Finnish
				+R707			French
				+R708			Spanish
				+R709			Portuguese (Portugal)
+R711			Russian				
+R712			Chinese				
+R714			Turkish				
+R713			Polish				

RATINGS, TYPES AND VOLTAGES

1-phase, $U_N = 230$ V (range 200 to 240 V). The power ratings are valid at nominal voltage 230 V (0.25 to 3.0 kW).

Drive type	Frame size	Nominal ratings		Light-duty use		Heavy-duty use		Max. output current I_{MAX} (A)
		I_N (A)	P_N (kW)	I_{Ld} (A)	P_{Ld} (kW)	I_{Hd} (A)	P_{Hd} (kW)	
ACS380-04xx-02A4-1	R0	2.4	0.37	2.3	0.37	1.8	0.25	3.2
ACS380-04xx-03A7-1	R0	3.7	0.55	3.5	0.55	2.4	0.37	4.3
ACS380-04xx-04A8-1	R1	4.8	0.75	4.6	0.75	3.7	0.55	6.7
ACS380-04xx-06A9-1	R1	6.9	1.1	6.6	1.1	4.8	0.75	8.6
ACS380-04xx-07A8-1	R1	7.8	1.5	7.4	1.5	6.9	1.1	12.4
ACS380-04xx-09A8-1	R2	9.8	2.2	9.3	2.2	7.8	1.5	14.0
ACS380-04xx-12A2-1	R2	12.2	3.0	11.6	3.0	9.8	2.2	17.6

3-phase, $U_N = 230$ V (range 200 to 240 V). The power ratings are valid at nominal voltage 230 V (0.25 to 15 kW).

Drive type	Frame size	Nominal ratings		Light-duty use		Heavy-duty use		Max. output current I_{MAX} (A)
		I_N (A)	P_N (kW)	I_{Ld} (A)	P_{Ld} (kW)	I_{Hd} (A)	P_{Hd} (kW)	
ACS380-04xx-02A4-2	R1	2.4	0.37	2.3	0.37	1.8	0.25	3.2
ACS380-04xx-03A7-2	R1	3.7	0.55	3.5	0.55	2.4	0.37	4.3
ACS380-04xx-04A8-2	R1	4.8	0.75	4.6	0.75	3.7	0.55	6.7
ACS380-04xx-06A9-2	R1	6.9	1.1	6.6	1.1	4.8	0.75	8.6
ACS380-04xx-07A8-2	R1	7.8	1.5	7.5	1.5	6.9	1.1	12.4
ACS380-04xx-09A8-2	R1	9.8	2.2	9.3	2.2	7.8	1.5	14.0
ACS380-04xx-12A2-2	R2	12.2	3.0	11.6	3.0	9.8	2.2	17.6
ACS380-04xx-17A5-2	R3	17.5	4.0	16.7	4.0	12.2	3.0	22.0
ACS380-04xx-25A0-2	R3	25.0	5.5	24.2	5.5	17.5	4.0	31.5
ACS380-04xx-033A-2	R3	32.0	7.5	30.8	7.5	25.0	5.5	45.0
ACS380-04xx-048A-2	R4	48.0	11.0	46.2	11.0	32.0	7.5	57.6
ACS380-04xx-055A-2	R4	55.0	15.0	52.8	15.0	48.0	11.0	86.4

3-phase, $U_N = 400$ V (range 380 to 480 V). The power ratings are valid at nominal voltage 400 V (0.37 to 22 kW).

Drive type	Frame size	Nominal ratings		Light-duty use		Heavy-duty use		Max. output current I_{MAX} (A)
		I_N (A)	P_N (kW)	I_{Ld} (A)	P_{Ld} (kW)	I_{Hd} (A)	P_{Hd} (kW)	
ACS380-04xx-01A8-4	R0	1.8	0.55	1.7	0.55	1.2	0.37	2.2
ACS380-04xx-02A6-4	R1	2.6	0.75	2.5	0.75	1.8	0.55	3.2
ACS380-04xx-03A3-4	R1	3.3	1.1	3.1	1.1	2.6	0.75	4.7
ACS380-04xx-04A0-4	R1	4.0	1.5	3.8	1.5	3.3	1.1	5.9
ACS380-04xx-05A6-4	R1	5.6	2.2	5.3	2.2	4.0	1.5	7.2
ACS380-04xx-07A2-4	R1	7.2	3.0	6.8	3.0	5.6	2.2	10.1
ACS380-04xx-09A4-4	R1	9.4	4.0	8.9	4.0	7.2	3.0	13.0
ACS380-04xx-12A6-4	R2	12.6	5.5	12.0	5.5	9.4	4.0	16.9
ACS380-04xx-17A0-4	R3	17.0	7.5	16.2	7.5	12.6	5.5	22.7
ACS380-04xx-25A0-4	R3	25.0	11.0	23.8	11.0	17.0	7.5	30.6
ACS380-04xx-033A-4	R3	32.0	15.0	30.5	15.0	25.0	11.0	45.0
ACS380-04xx-038A-4	R4	38.0	18.5	36.0	18.5	32.0	15.0	57.6
ACS380-04xx-045A-4	R4	45.0	22.0	42.8	22.0	38.0	18.5	68.4
ACS380-04xx-050A-4	R4	50.0	22.0	48.0	22.0	45.0	22.0	81.0

Nominal ratings

I_N	Nominal output current available continuously without overloadability at 50 °C.
P_N	Typical motor power in no-overload use.

Maximum output current

I_{max}	Maximum output current. Available for 2 seconds at start, then as long as allowed by drive temperature.
-----------	---

Heavy-duty use

I_{Hd}	Output current allowing 150% I_{Hd} for 1 minute every 10 minutes at 50 °C.
P_{Hd}	Typical motor power in heavy-duty use.

Light-duty use

I_{Ld}	Output current allowing 110% I_{Ld} for 1 minute every 10 minutes at 50 °C.
P_{Ld}	Typical motor power in light-overload use.

The ratings apply at 50 °C ambient temperatures. For derating at higher altitudes, temperatures or switching frequencies, see the user's HW manual, document code: 3AXD50000029274.

DIMENSIONS

Dimensions and weights (IP20 / UL open type)											
Frame size	H1 (mm)	H2 (mm)	H3 (mm)	W1 (mm)	W2 (mm)	W3 (mm)	D1 (mm)	D2 (mm)	M1 (mm)	M2 (mm)	Weight (kg)
R0	205	223	170	70	86	94	176	191	50	191	1.4
R1	205	223	170	70	86	94	176	191	50	191	1.4
R2	205	223	170	95	111	119	176	191	75	191	2.0
R3	205	223	170	170	186	194	176	191	148	191	3.3
R4	205	240	170	260	276	284	181	196	234	191	5.3

H1 = Mounting surface height (back)
H2 = Height, total
H3 = Enclosure height (front)
W1 = Width without side option
W2 = Width with side option BAPO-01
W3 = Width with side options BTAC-02, BREL-01
D1 = Depth
D2 = Depth with deeper cover *)
M1 = Mounting hole distance 1
M2 = Mounting hole distance 2
 *) Deeper cover (with BIO-01 or FSPS-21) will increase normal depth (D1) by 15 mm

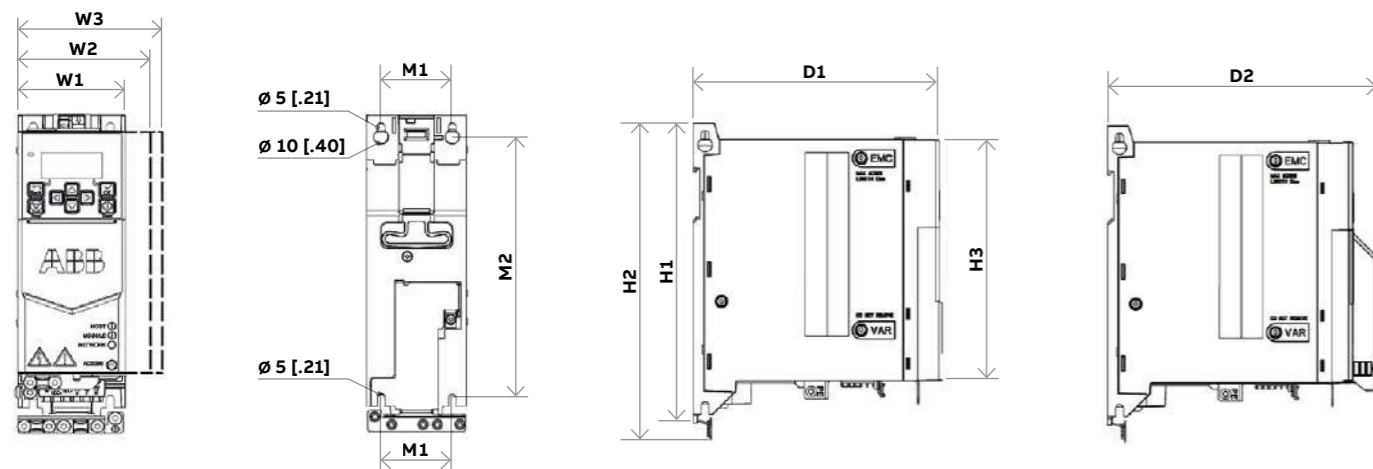

Dimensions and weights (drive with UL type 1 kit)											
Frame size	H1 (mm)	H2 (mm)	H3 (mm)	W1 (mm)	W2 (mm)	W3 (mm)	D (mm)	M1 (mm)	M2 (mm)	Weight (kg)	
R0	205	285	247	70	86	94	191	50	191	1.8	
R1	205	293	247	70	86	94	191	50	191	1.8	
R2	205	293	247	95	111	119	191	75	191	2.5	
R3	205	329	261	170	186	194	191	148	191	4.0	
R4	205	391	312	260	276	284	196	234	191	6.5	

H1 = Mounting surface height (back)
H2 = Height with UL Type 1 kit, total
H3 = Height with UL type 1 kit, enclosure (front)
W1 = Width without side option
W2 = Width with side option BAPO-01
W3 = Width with side options BTAC-02, BREL-01
D = Depth
M1 = Mounting hole distance 1
M2 = Mounting hole distance 2

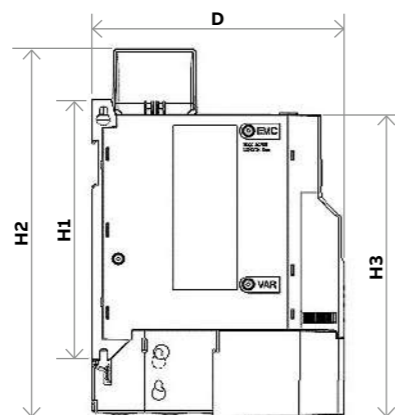

CONSTRUCTION VARIANTS

The ACS380 machinery drive comes in several variants ensuring seamless integration into machines and connecting perfectly to automation systems.

Standard variant (ACS380-04xS)

Meets the most typical machinery requirements.

A standard variant (ACS380-04xS) includes BMIO-01 module in the delivery to support Modbus RTU and a wide range of digital and analog I/O. In addition, this construction variant has one side option slot. Options are available as loose items via mrp ordering codes.

- The standard variant includes:**
- 4 DI + 2 DI/DO + 2 AI + 1 AO + 1 RO + STO
 - Embedded Modbus RTU

DEFAULT I/O CONNECTIONS OF STANDARD VARIANT (ACS380-04XS)

Terminals	Descriptions
Aux. voltage output and digital connections	
+24 V	Aux. voltage output +24 V DC, max. 250 mA
DGND	Aux. voltage output common
DCOM	Digital input common for all
DI 1	Digital input 1: Stop (0)/Start (1)
DI 2	Digital input 2: Forward (0)/Reverse (1)
DI 3	Digital input 3: Speed selection
DI 4	Digital input 4: Speed selection
DIO 1	Digital input function: Ramp set 1 (0)/Ramp set 2 (1)
DIO 2	Digital output function: Ready to run (0)/Not ready (1)
DIO SRC	Signal cable shield (screen)
DIO COM	Digital input common for all
Reference voltage and analog I/O	
AI 1	Output frequency/Speed reference (0...10 V)
AGND	Analog input circuit common
AI 2	Not configured
AGND	Analog input circuit common
AO	Output frequency (0...20 mA)
AGND	Analog output circuit common
SCR	Signal cable shield (screen)
+10 V	Reference voltage
Safe Torque Off (STO)	
S+	Safe Torque Off function. Connected at the factory.
SGND	The drive starts only when both circuits are closed. Refer to the Safe Torque Off function in the hardware manual.
S 1	
S 2	
Relay output	
RC	No fault [Fault (-1)]
RA	
RB	
EIA-485 Modbus RTU	
B+	Embedded Modbus RTU (EIA-485)
A-	
BGND	
Shield	
Termination	

DEFAULT I/O CONNECTIONS OF THE STANDARD VARIANT

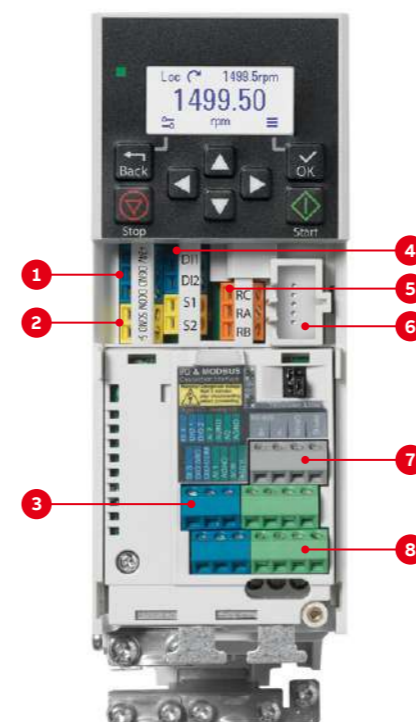

1. Auxiliary voltage outputs
2. Safe Torque Off connections
3. Digital inputs and outputs
4. Digital inputs
5. Relay output connection
6. Cold configuration connection for CCA-01
7. EIA-485 Modbus RTU
8. Analog inputs and outputs

CONSTRUCTION VARIANTS

Configured variant (ACS380-04xC)

Simplified ordering by one single ordering code and possibility for preinstalled options.

A configured variant (ACS380-04xC) can be configured with different options covering digital and analog I/O, fieldbus communication, speed feedback and external 24 V DC supply.

The configured variant includes:

- 2 DI + 1 RO + STO + one preconfigured fieldbus

Options ordered with the pluscode. (See pluscodes, page 16):

Fieldbus options

PROFIBUS, PROFINET/PROFIsafe, EtherNet/IP™, Modbus TCP/IP, OPC UA, EtherCAT®, POWERLINK, DeviceNet™, CanOpen®

One of following side options

- HTL/TTL encoder & ext. 24 V DC supply (BTAC-02)
- 4 x relay output module (BREL-01)
- External 24 V DC supply (BAPO-01)

One front I/O option

can be used together with fieldbus
3 DI + 1 DO + 1 AI + 1 AO (BIO-01)

DEFAULT CONNECTIONS OF CONFIGURED VARIANT (ACS380-04XC)

Terminals	Descriptions
Aux. voltage output and digital connections	
+24 V	Aux. voltage output +24 V DC, max. 250 mA
DGND	Aux. voltage output common
DCOM	Digital input common for all
DI 1	Digital input 1: Stop (0)/Start (1)
DI 2	Digital input 2: Forward (0)/Reverse (1)
Safe Torque Off (STO)	
S+	Safe Torque Off function. Connected at the factory. The drive starts only when both circuits are closed. Refer to the Safe Torque Off function in the hardware manual.
SGND	
S 1	
S 2	
Relay output	
RC	Fault (-1)
RA	250 V AC/30 V DC
RB	2 A
Option module connections	
See table on page 17 for available fieldbus connection options and table on page 22 for I/O options.	

ACS380 CONFIGURED VARIANT (ACS380-04XC)



Base variant (ACS380-04xN)

Offers maximum flexibility with minimum stock items for varying machine building needs.

Base variant can be ordered with any of the connectivity or I/O option as loose item.

Options:

Fieldbus options

PROFIBUS, PROFINET/PROFIsafe, EtherNet/IP™, CIP Safety, Modbus TCP/IP, OPC UA, EtherCAT®, POWERLINK, DeviceNet™, CanOpen®

One of following side options

- HTL/TTL encoder & ext. 24 V DC supply (BTAC-02)
- 4 x relay output module (BREL-01)
- External 24 V DC supply (BAPO-01)

One front I/O option

can be used together with fieldbus
3 DI + 1 DO + 1 AI + 1 AO (BIO-01)

DEFAULT CONNECTIONS OF BASE VARIANT (ACS380-04XN)

Terminals	Descriptions
Aux. voltage output and digital connections	
+24 V	Aux. voltage output +24 V DC, max. 250 mA
DGND	Aux. voltage output common
DCOM	Digital input common for all
DI 1	Digital input 1: Stop (0)/Start (1)
DI 2	Digital input 2: Forward (0)/Reverse (1)
Safe Torque Off (STO)	
S+	Safe Torque Off function. Connected at the factory. The drive starts only when both circuits are closed. Refer to the Safe Torque Off function in the hardware manual.
SGND	
S 1	
S 2	
Relay output	
RC	Fault (-1)
RA	250 V AC/30 V DC
RB	2 A
Option module connections	
See table on page 17 for available fieldbus connection options and table on page 22 for I/O options.	

ACS380 BASE VARIANT (ACS380-04XN)



CONTROL PANEL OPTIONS AND MOUNTING KITS

The ACS380 drive has an integrated control panel with a display and control keys. Also, external control panels are available for installation to a cabinet door or for operation via Bluetooth connection.



Integrated control panel
Almost anyone can set up and commission the machinery drive using the available control panels. The ACS380 comes with the integrated icon-based control panel as standard. You do not need to know any drive parameters as the control panel helps you to set up the essential settings quickly and get the drive into action. In addition, ACS380 supports the assistant control panel (AP-I, AP-S or AP-W).



Assistant control panel, ACS-AP-I *)
The optional Assistant control has a graphical, multilingual display. There is no need to know any drive parameters, as the control panel helps you set up the essential settings quickly and get the drive into action without hassle. The panel can be used with any products in the ABB all-compatible product portfolio.



Bluetooth control panel, ACS-AP-W *)
The optional Bluetooth panel enables connection with the Drivetune mobile app. The app is available for free from Google Play and the Apple App Store. Together with the Drivetune app and the Bluetooth panel, users can, for example, commission and monitor the drive remotely.



Basic control panel, ACS-BP-S
If there is a need to install a basic panel into the cabinet door, the ACS-BP-S is the right choice. The icon-based control panel supports users with basic operation, settings and fault tracking when nothing extra is needed.



Control panel mounting platform, DPMP-01
This mounting platform is for flush mountings. The panel mounting platform does not include the control panel.



Control panel mounting platform, DPMP-02
This mounting platform is for surface mounting. The panel mounting platform does not include the control panel.



Control panel mounting platform, DPMP-04
Enables control panel outdoor mounting thanks to IP66 protection class, UV resistance and IK07 impact protection rating.

Control panel options		
Ordering code	Description	Control panel
3AUA0000088311	Industrial assistant control panel *)	ACS-AP-I
3AUA0000064884	Assistant control panel	ACS-AP-S
3AXD0000025965	Assistant control panel with bluetooth interface *)	ACS-AP-W
3AXD50000028828	Basic control panel	ACS-BP-S
3AUA0000108878	Control panel mounting platform (flush mounted)	DPMP-01
3AXD50000009374	Control panel mounting platform (surface mounted)	DPMP-02
3AXD50000217717	Control panel mounting platform (outdoor installation)	DPMP-04

*) Also compatible with the following ABB all-compatible drives: ACS480, ACS580 and ACS880.

DOOR MOUNTING AND DAISY CHAINING

Improve safety and leverage the full potential of the ACS380 control panel options with a door mounting kit and panel bus adapter.



Door mounting fosters easy operation and safety. It enables you to operate the drive without opening the cabinet door, saving time and keeping all the electronics behind the closed door. Up to 32 drives can be connected to one control panel

for even easier and quicker operation. When daisy chaining the drives, you need only one assistant control panel. The rest of the drives can be equipped with panel bus adapters and the last drive with termination plug.

Cabinet door

Control panel mounting platform
The mounting platform for the drive's control panel.

Assistant control panel
The assistant control panel can be selected with ACS380 drives. Also a Bluetooth control panel can be used.

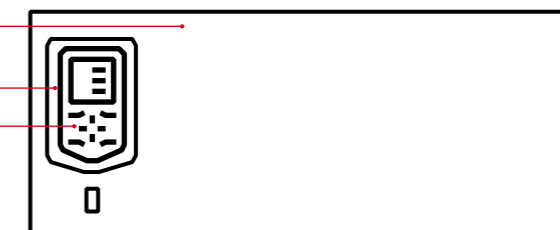

Cabinet, outside

RJ-45 cable for daisy chaining drives
With BSPL-01 Panel bus adapter and panel bus termination plug.

Panel bus adapter is required for each drive and termination plug only for the last drive.

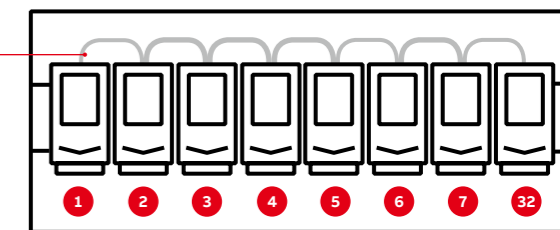

Cabinet, inside

TOOLS FOR CONFIGURATION, MONITORING AND PROCESS TUNING

ACS380 has various tools to simplify the commissioning, operation and monitoring of the drive.



Easy configuration for unpowered drives

With the CCA-01 tool, it is possible to configure drive parameters and even download new software from PC to the unpowered ACS380. The power is supplied by a PC USB port.



Connection with cable

Using the BCBL-01 cable, the PC can be connected directly to the RJ-45 panel port on the ACS380 drive.



Drive Composer

The Drive Composer PC tool offers fast and harmonized setup, commissioning and monitoring. Drive Composer entry (a free version of the tool) provides startup and maintenance capabilities and gathers all drive information, such as parameter loggers, faults, and backups into a support diagnostics file.

Drive Composer pro provides additional features such as custom parameter windows, graphical control diagrams of the drive's configuration, and improved monitoring and diagnostics.



Connection to assistant panel

When using the Assistant control panel, the Drive composer tool is connected to the drive using the mini USB connection on the panel.

FLEXIBLE CONNECTIVITY TO AUTOMATION NETWORKS

Fieldbus communication reduces wiring costs compared with traditional hard-wired input/output connections.

The ACS380 configured variant is compatible with a wide range of fieldbus protocols. Fieldbus adapter modules are automatically configured during first power up, thus reducing commissioning time and allowing drive commissioning from the PLC. The ACS380 standard variant comes with built-in Modbus RTU protocol.

Support tools for integration with automation

Support for the fieldbuses is not always enough to get the full functionality and to make integration easy. For this reason, ABB also offers tools for seamless integration to automation systems of various manufacturers.



UNIVERSAL COMMUNICATION WITH ABB FIELDBUS ADAPTERS

The machinery drives support the following fieldbus protocols:

Ordering code	Description	Type designation
3AXD50000032449	PC cable, USB to RJ45	BCBL-01
3AXD50000019865	Cold configurator adapter, packed kit	CCA-01
3AUA0000108087	Drive Composer pro PC tool (single user license)	DCPT-01
3AUA0000145150	Drive Composer pro PC tool (10 users license)	DCPT-01
3AUA0000145151	Drive Composer pro PC tool (20 users license)	DCPT-01
3AXD50000131976	Panel bus adapter	BSPL-01
3AXD50000128624	Panel bus termination plug	BPLG-01

Option code	Ordering code	Fieldbus protocol	Adapter module
+K451	68469341	DeviceNet™	FDNA-01
+K454	68469325	PROFIBUS DP, DPV0/DPV1	FPBA-01
+K457	68469376	CANopen®	FCAN-01
+K462	3AUA0000094512	ControlNet™	FCNA-01
+K469	3AUA0000072069	EtherCAT®	FECA-01
+K470	3AUA0000072120	Ethernet POWERLINK	FEPL-02
+K490	3AXD50000192786	Ethernet/IP™ and OPC UA	FEIP-21
+K491	3AXD50000049964	Modbus/TCP and OPC UA	FMBT-21
+K492	3AXD50000192779	PROFINET IO and OPC UA	FPNO-01
+K495	3AXD50000033816	CANopen® (screw terminals)	BCAN-11

Free Drive Composer entry available at <https://new.abb.com/drives/software-tools/drive-composer>

FUNCTIONAL SAFETY OPTIONS

Ensure the safety of your machinery and processes with drive-based functional safety

Integrated safety

Integrated safety reduces the need for external safety components, simplifying configuration and reducing installation space. The safety functionality is a built-in feature of the ACS380, with Safe Torque Off (STO) as standard. ACS380 can also be part of PROFIsafe over PROFINET network or Common Industrial Protocol (CIP Safety) over EtherNet/IP.

The drives' functional safety is designed in accordance with EN/IEC 61800-5-2 and complies with the requirements of the European Union Machinery Directive (2006/42/EC). The safety functions are certified by TÜV Nord and comply with the highest safety performance level (SIL 3/PL e) for machinery safety. It is possible to install the safety modules also afterwards to the drive.

CIP Safety™ functions module FSCS-21 and PROFIsafe safety functions module FSPS-21

The FSCS-21 module operates through the EtherNet/IP™ communication protocol. Common Industrial Protocol (CIP Safety) over EtherNet/IP enables a single-cable solution for safety and non-safety control. It features the ready-made safe stopping functions Safe Torque Off and Safe Stop 1 (SS1-t), a time-controlled function.

The FSPS-21 module has integrated PROFIsafe, safety functions and PROFINET IO connection. The ready-made safety functions make safety configuration in the drive unnecessary. The module supports STO and SS1-t safety functions. It is used together with a safety PLC that supports PROFIsafe over PROFINET communication.

For more information about FSPS-21 PROFIsafe safety functions module and FSCS-21 CIP safety functions module see new.abb.com/drives/functional-safety

Safe Torque Off (STO)

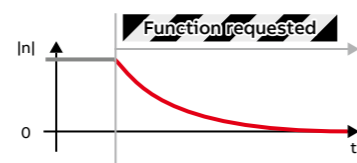

STO is the basic foundation of drive-based functional safety, as it brings a drive safely to no-torque state making the motor coast to stop. Integrated STO-function simplifies the safety circuit as external components are not needed to safely stop the application.

- **STO** is a standard safety function in all ABB drives.
- Typically used for prevention of an unexpected startup (EN ISO 14118) of machinery or for an emergency stop, fulfilling stop category 0 (EN 13850 / IEC 60204-1).

Safe Stop 1, time controlled (SS1-t)

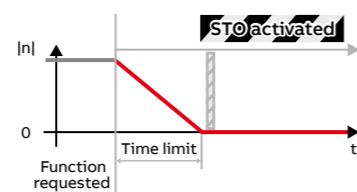

Safe Stop 1 stops the motor safely with a controlled ramp stop and stop time monitoring. SS1-t initiates the ramp stop from the drive and activates STO when speed reaches zero. If the drive is not decelerating to zero speed within the time limit, the STO function is activated. SS1-t is typically used in applications where motion must be stopped quickly and safely before switching to a no-torque state.

- **SS1-t** stops the motor safely, using a controlled ramp stop and then activates the STO function.
- **SS1-t** can be used to implement an Emergency stop, fulfilling stop category 1 (EN/IEC 60204-1).



Safety function modules		
Option code	Ordering code	Module
+Q986	3AXD5000112821	FSPS-21
-	3AXD50001021061	FSCS-21

Note: These modules are not compatible with other fieldbus option modules for ACS380 drives.

Example: SS1-t

Safety function module FSPS-21, functionality cycle

0. Drive running

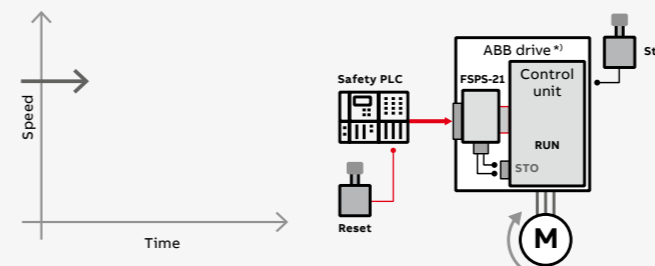

1. Safety PLC – safety function request to the FSPS-21

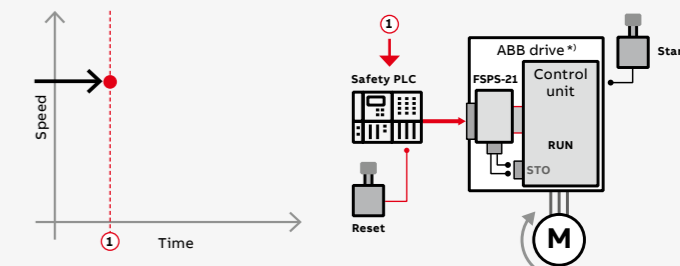

2. SS1-t, safety functions request / start of monitoring

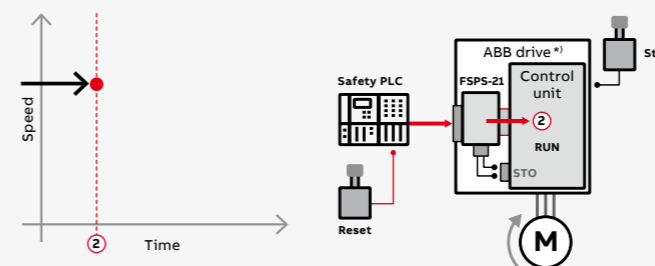

3. Transition and time monitoring of the SS1-t

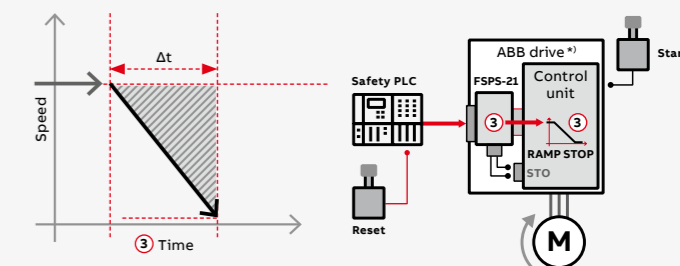

4. Zero speed or SS1-t time limit reached / STO is opened

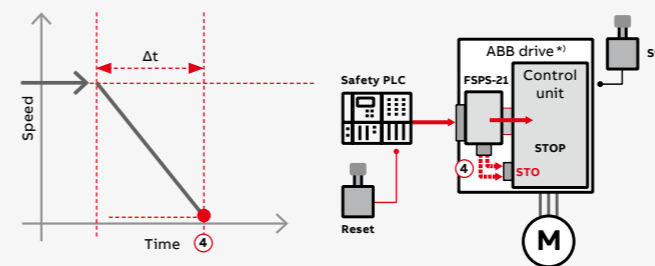

5. Safe state / STO is open

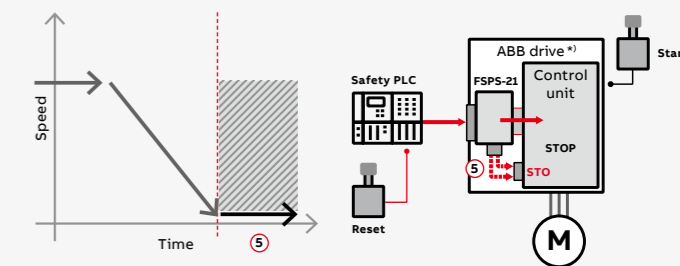

6. Safety function request removed / reset / STO is closed

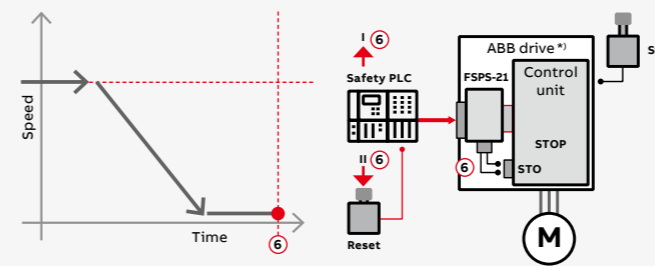

7. Start – return to normal operation

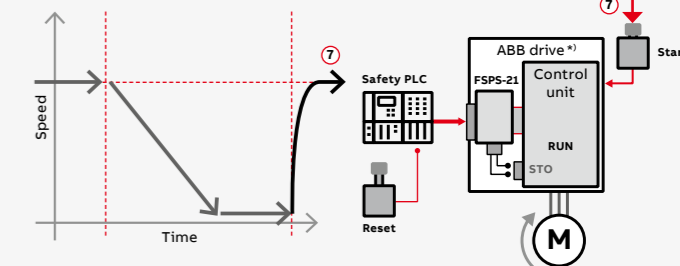

* The ABB drive can be ACS380, ACS580 or ACS880

ABB DRIVES AND OPC UA

A future proof and effective solution for data and asset management

Security, ease of use and interoperability are all features of OPC UA. ABB drives support OPC UA for data collection which means that ABB drives are equipped with OPC UA Server.

Any OPC UA Client can be connected to ABB drives and start collecting data for their purposes. By this way for example active faults, event history, active value such as power, torque and current can be accessed by OPC UA Clients securely.

This data can be used in process monitoring, asset management and for centralized event management on site, edge or in cloud via a gateway.



Benefits

- Provide a secure connection
- Server-client based connection between devices
- Event logger visibility
- A harmonized information model is provided across drive portfolio
- Utilizes single wire connection to the drive, Ethernet based protocol
- ABB or a third part OPC UA Client can fetch the data from the drive
- OPC UA Server is embedded into the PROFINET, Modbus TCP and EtherNet/IP fieldbus adapters

OPC UA is a communication protocol for interoperability and data exchange between different devices, systems and applications.

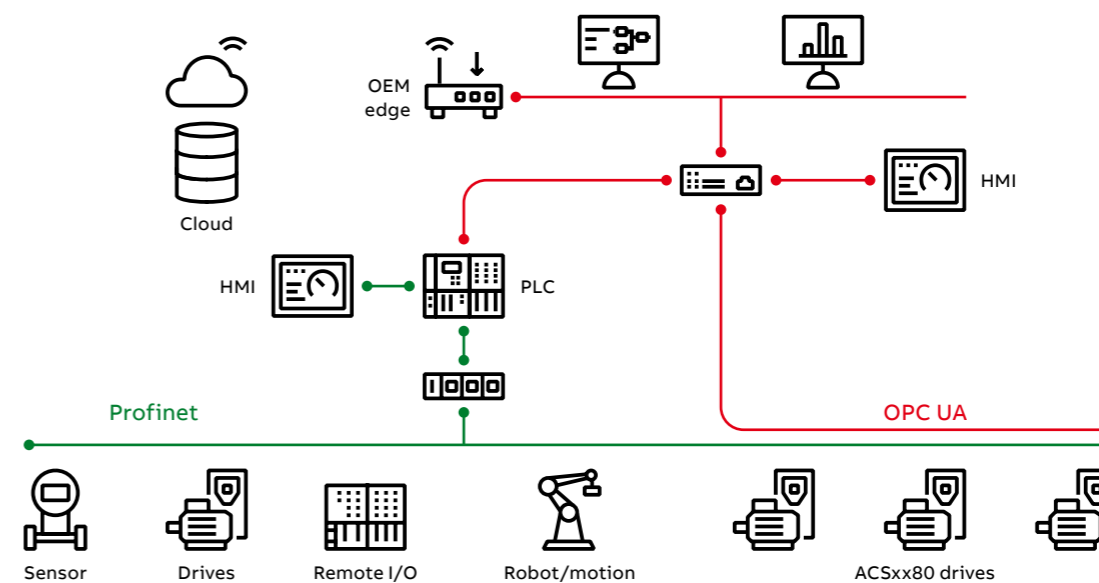

<https://new.abb.com/drives/connectivity/opc-ua-for-drives>

I/O OPTION MODULES



ACS380 drives can be ordered with different I/O configurations. The standard input and output of the drive can be extended by using I/O option modules. A BIO-01 module extends the configured variant's I/O, whereas a BMIO-01 module provides both additional I/O and Modbus. In case additional relay outputs are needed, they can be added with a BREL-01 module. A BAPO-01 module introduces an external 24 V DC supply to the drive's control circuits.

The ACS380 drive's open loop performance is sufficient for almost any application, even when accurate control is needed close to zero speed. However, if speed feedback is needed for even more accurate control or for active loads like hoists, a speed feedback module BTAC-02 adds support for TTL and HTL pulse encoders.

I/O option modules			
Option code	Ordering code	Description	Module
+L511	3AXD50000022162	External relay option, 4 x RO (side option)	BREL-01
+L515	3AXD50000191635	I/O option (front option). Can be used together with fieldbus.	BIO-01
+L534	3AXD50000022164	External 24 V DC (side option)	BAPO-01
+L535	3AXD50000022163	HTL/TTL encoder interface + External 24 V DC (side option)	BTAC-02
+L538	3AXD50000021262	I/O & Modbus extension (front option)	BMIO-01

I/O	Base unit (ACS380-04xx)	BMIO-01 (ACS380-04x5)	BIO-01	BREL-01
Inputs				
Digital inputs	2 (DI1, DI2)	4 (DI3, DI4, DIO1, DIO2)	3 (DI3, DI4, DI5)	-
Frequency inputs	-	2 (DI3, DI4)	2 (DI4, DI5)	-
Counter inputs	-	1 (DI3)	1 (DI4)	-
Analog inputs	-	2 (AI1, AI2)	1 (AI1)	-
Outputs				
Relay outputs	1 (RO1)	-	-	4 (RO4, RO5, RO6, RO7)
Digital outputs	-	2 (DIO1, DIO2)	1 (DIO1)	-
Frequency outputs	-	2 (DIO1, DIO2)	1 (DIO1)	-
Analog outputs	-	1 (AO1)	1 (AO1)	-

Note: The number of inputs and outputs depends on the configuration. For example, DIO can be configured as digital input or output.

RESISTOR BRAKING

Brake chopper

The brake chopper is built in as standard for the ACS380. It not only controls braking, but also supervises system status and detects failures such as brake resistor and resistor cable short-circuits, chopper short-circuit, and calculated resistor over-temperature. See the tables for internal brake chopper specifications for each drive type.

Brake resistor

The brake resistors are separately available for the ACS380. Resistors other than the standard option resistors may be used, provided that the specified resistance value is higher than the minimum resistance and that heat dissipation capacity of the resistor is sufficient for the drive application (see hardware manual). No separate fuses in the brake circuit are required if the conditions for the mains cable, for example, are protected with fuses and no mains cable/fuse overrating occurs.

Drive type	Frame size	Internal brake chopper				Example brake resistor Danotherm type
		R_{min} (ohm)	R_{max} (ohm)	P_{BRcont} (kW)	P_{BRmax} (kW)	
1-phase 230 V						
ACS380-04xx-02A4-1	R0	32.5	468	0.25	0.38	
ACS380-04xx-03A7-1	R0	32.5	316	0.37	0.56	CBH 360 C T 406 210R, CAR 200 D T 406 210R
ACS380-04xx-04A8-1	R1	32.5	213	0.55	0.83	
ACS380-04xx-06A9-1	R1	32.5	145	0.75	1.10	CBR-V 330 D T 406 78R UL
ACS380-04xx-07A8-1	R1	32.5	96.5	1.10	1.70	
ACS380-04xx-09A8-1	R2	32.5	69.9	1.50	2.30	
ACS380-04xx-12A2-1	R2	19.5	47.1	2.20	3.30	CBR-V 560 D HT 406 39R UL
3-phase 230 V						
ACS380-04xx-02A4-2	R1	39	474	0.25	0.38	
ACS380-04xx-03A7-2	R1	39	319	0.37	0.56	CBH 360 C T 406 210R, CAR 200 D T 406 210R
ACS380-04xx-04A8-2	R1	39	217	0.55	0.83	
ACS380-04xx-06A9-2	R1	39	145	0.75	1.13	CBR-V 330 D T 406 78R UL
ACS380-04xx-07A8-2	R1	39	105	1.10	1.65	
ACS380-04xx-09A8-2	R1	20	71	1.50	2.25	CBR-V 560 D HT 406 39R UL
ACS380-04xx-12A2-2	R2	20	52	2.20	3.30	
ACS380-04xx-17A5-2	R3	16	38	3.00	4.50	CBT-H 560 D HT 406 19R
ACS380-04xx-25A0-2	R3	16	28	4.00	6.00	
ACS380-04xx-033A-2	R3	8	17	5.50	8.25	CBT-H 560 D HT 406 15R
ACS380-04xx-048A-2	R4	3	14	7.50	11.25	CBT-V 760 G H T 282 8R
ACS380-04xx-055A-2	R4	3	10	11.00	16.50	
3-phase 400 V						
ACS380-04xx-01A8-4	R0	99	933	0.37	0.56	
ACS380-04xx-02A6-4	R1	99	628	0.55	0.83	
ACS380-04xx-03A3-4	R1	99	428	0.75	1.13	CBH 360 C T 406 210R, CAR 200 D T 406 210R
ACS380-04xx-04A0-4	R1	99	285	1.10	1.65	
ACS380-04xx-05A6-4	R1	99	206	1.50	2.25	
ACS380-04xx-07A2-4	R1	53	139	2.20	3.30	
ACS380-04xx-09A4-4	R1	53	102	3.00	4.50	CBR-V 330 D T 406 78R UL
ACS380-04xx-12A6-4	R2	32	76	4.00	6.00	
ACS380-04xx-17A0-4	R3	32	54	5.50	8.25	CBR-V 560 D HT 406 39R
ACS380-04xx-25A0-4	R3	23	39	7.50	11.25	
ACS380-04xx-033A-4	R3	16	33	11.00	17.00	CBR-V 560 D HT 406 19R
ACS380-04xx-038A-4	R4	6	24	15.00	23.00	
ACS380-04xx-045A-4	R4	6	20	18.50	28.00	CBT-H 760 D HT 406 16R
ACS380-04xx-050A-4	R4	6	20	22.00	33.00	

R_{min} = The minimum permitted resistance value of the brake resistor

R_{max} = The maximum resistance value of the brake resistor that can provide P_{BRcont}

P_{BRcont} = The continuous braking capacity of the drive

P_{BRmax} = The maximum braking capacity of the drive, when the length of the braking pulse is at most 1 minute for each 10 minutes ($P_{BRcont} \times 1.5$). The maximum braking capacity must be more than the desired braking power.

Example brake resistor → Check the allowed braking cycle from the resistor data sheet.
See the ACS380 HW manual (3AXD50000029274) for braking resistor dimension guidelines.

EMC – ELECTROMAGNETIC COMPATIBILITY

The ACS380 machinery drives are equipped with a built-in filter to reduce high-frequency emissions. Low EMC filters (C3 for 400 V and C4 for 230 V) are denoted by type code ACS380-040X and high EMC filters (C2 for all voltages) by type code ACS380-042X. C1 can be achieved with an external EMC filter.

EMC standards

The EMC product standard (EN 61800-3) covers the specific EMC requirements stated for drives (tested with motor and cable) within the EU. EMC standards such as EN 55011 or EN 61000-6-3/4 are applicable to industrial and domestic equipment and systems including components inside the drive. Drive units complying with the requirements of EN 61800-3 are compliant with comparable categories

in EN 55011 and EN 61000-6-3/4, but not necessarily vice versa. EN 55011 and EN 61000-6-3/4 do not specify cable length or require a motor to be connected as a load. The emission limits are comparable to EMC standards according to the table below.

Domestic environments versus public low voltage networks

The first environment includes domestic premises. It also includes establishments directly connected without an intermediate transformer to a low voltage power supply network that supplies buildings used for domestic purposes. The second environment includes all establishments directly connected to public low voltage power supply networks.

Comparison of EMC standards

EMC according to EN 61800-3 product standard	EN 61800-3 product standard	EN 55011, product family standard for industrial, scientific and medical (ISM) equipment	EN 61000-6-4, generic emission standard for industrial environments	EN 61000-6-3, generic emission standard for residential, commercial and light-industrial environments
1 st environment, unrestricted distribution	Category C1	Group 1, Class B	Not applicable	Applicable
1 st environment, restricted distribution	Category C2	Group 1, Class A	Applicable	Not applicable
2 nd environment, unrestricted distribution	Category C3	Group 2, Class A	Not applicable	Not applicable
2 nd environment, restricted distribution	Category C4	Not applicable	Not applicable	Not applicable

EMC compliance and maximum motor cable length

Voltage (Product variant)	Frame size	EMC category (EN 61800-3), max. motor cable length		
		C1	C2	C3
With internal / external filter				
1-phase 230 V (ACS380-04xx-xxxx-1)	R0	- / 10 m	10 m / 10 m	10 m / 10 m
	R1	- / -	10 m / -	10 m / -
	R2	- / -	10 m / -	10 m / -
3-phase 230 V (ACS380-04xx-xxxx-2)	R1	- / -	- / 20 m	- / 20 m
	R2	- / -	- / 20 m	- / 20 m
	R3	- / -	- / 20 m	- / 20 m
	R4	- / -	- / 20 m	- / 20 m
3-phase 400 V (ACS380-04xx-xxxx-4)	R0	- / 30 m	10 m / 30 m	30 m / 30 m
	R1	- / 30 m	10 m / 30 m	30 m / 40 m
	R2	- / 40 m	10 m / 40 m	20 m / 40 m
	R3	- / 40 m	10 m / 40 m	30 m / 40 m
	R4	- / 30 m	10 m / 30 m	30 m / 30 m

• Internal filter: C2 with ACS380-042x-xxxx-x, C3 with ACS380-040x-xxxx-4

• External filter: Please see page 29 Filters and chokes for the suitable external filter type

FILTERS AND CHOKES

It is advisable to use a mains choke if the short-circuit capacity of the network at the drive terminals is higher than specified in the table.

Frame size / voltage rating	R0, R1, R2	R3, R4
1-phase 230 V	>5.0 kA	>7.5 kA
3-phase 230 V	>5.0 kA	>7.5 kA
3-phase 380...480 V	>5.0 kA	>10 kA

1-phase $U_N = 230$ V (range 200 to 240 V)

Drive type	Frame size	C1 filter ABB type / Schaffner type	Mains choke Max. ambient temp. 40 °C	du/dt filter Max. ambient temp. 40 °C
ACS380-04xx-02A4-1	R0	RFI-11 / FN21754-6.1-07	CHK-A1	ACS-CHK-B3
ACS380-04xx-03A7-1	R0	RFI12 / FN21754-16.1-07	CHK-B1	ACS-CHK-B3
ACS380-04xx-04A8-1	R1	RFI12 / FN21754-16.1-07	CHK-B1	ACS-CHK-B3
ACS380-04xx-06A9-1	R1	RFI12 / FN21754-16.1-07	CHK-C1	ACS-CHK-C3
ACS380-04xx-07A8-1	R1	RFI12 / FN21754-16.1-07	CHK-C1	ACS-CHK-C3
ACS380-04xx-09A8-1	R2	-	CHK-D1	ACS-CHK-C3
ACS380-04xx-12A2-1	R2	-	CHK-D1	ACS-CHK-C3

3-phase $U_N = 230$ V (range 200 to 240 V)

Drive type	Frame size	C1 filter ABB type / Schaffner type	Mains choke Max. ambient temp. 40 °C	du/dt filter Max. ambient temp. 40 °C
ACS380-04xx-02A4-2	R1	RFI 32 / FN 3258-16-44	CHK-01	-
ACS380-04xx-03A7-2	R1	RFI 32 / FN 3258-16-44	CHK-02	-
ACS380-04xx-04A8-2	R1	RFI 32 / FN 3258-16-44	CHK-03	-
ACS380-04xx-06A9-2	R1	RFI 32 / FN 3258-16-44	CHK-03	-
ACS380-04xx-07A8-2	R1	RFI 32 / FN 3258-16-44	CHK-03	-
ACS380-04xx-09A8-2	R1	RFI 32 / FN 3258-16-44	CHK-04	-
ACS380-04xx-12A2-2	R2	RFI-33 / FN 3258-30-33	CHK-04	-
ACS380-04xx-17A5-2	R3	RFI-33 / FN 3258-30-33	CHK-04	-
ACS380-04xx-25A0-2	R3	RFI-33 / FN 3258-30-33	CHK-06	-
ACS380-04xx-033A-2	R3	RFI-34 / FN3258-100-35	CHK-06	-
ACS380-04xx-048A-2	R4	RFI-34 / FN3258-100-35	CHK-07	-
ACS380-04xx-055A-2	R4	RFI-34 / FN3258-100-35	CHK-07	-

3-phase $U_N = 400$ V (range 380 to 480 V)

Drive type	Frame size	C1 filter ABB type / Schaffner type	Mains choke Max. ambient temp. 40 °C	du/dt filter Max. ambient temp. 40 °C
ACS380-04xx-01A8-4	R0	RFI 32 / FN 3258-16-44	CHK-01	ACS-CHK-B3
ACS380-04xx-02A6-4	R1	RFI 32 / FN 3258-16-44	CHK-01	ACS-CHK-B3
ACS380-04xx-03A3-4	R1	RFI 32 / FN 3258-16-44	CHK-01	ACS-CHK-B3
ACS380-04xx-04A0-4	R1	RFI 32 / FN 3258-16-44	CHK-02	ACS-CHK-C3
ACS380-04xx-05A6-4	R1	RFI 32 / FN 3258-16-44	CHK-02	ACS-CHK-C3
ACS380-04xx-07A2-4	R1	RFI 32 / FN 3258-16-44	CHK-02	NOCH0016-6x
ACS380-04xx-09A4-4	R1	RFI 32 / FN 3258-16-44	CHK-03	NOCH0016-6x
ACS380-04xx-12A6-4	R2	RFI-33 / FN 3258-30-33	CHK-03	NOCH0016-6x
ACS380-04xx-17A0-4	R3	RFI-33 / FN 3258-30-33	CHK-04	NOCH0030-6x
ACS380-04xx-25A0-4	R3	RFI-34 / FN3258-100-35	CHK-04	NOCH0030-6x
ACS380-04xx-033A-4	R3	RFI-34 / FN3258-100-35	CHK-04	NOCH0030-6x
ACS380-04xx-038A-4	R4	RFI-34 / FN3258-100-35	CHK-06	NOCH0070-6x
ACS380-04xx-045A-4	R4	RFI-34 / FN3258-100-35	CHK-06	NOCH0070-6x
ACS380-04xx-050A-4	R4	RFI-34 / FN3258-100-35	CHK-07	NOCH0070-6x

COOLING, FUSES AND CIRCUIT BREAKERS

Cooling

ACS380 drives are fitted with variable-speed cooling air fans. The cooling air must be free from corrosive materials and must not exceed the maximum ambient temperature of 50 °C (60 °C with derating).*)

Fuse and circuit breakers

Standard fuses and circuit breakers can be used with the ACS380 drives. For input fuse or circuit breaker specifications, see the table below. Manual motor protectors can also be used. See ACS380 hardware manual for details.

The miniature circuit breakers listed below are tested and approved for use with the ACS380 drives. Other circuit breakers can also be used with the drive if they provide the same electrical characteristics.

Cooling air flow and recommended input protection fuses

1-phase $U_N = 230$ V (range 200 to 240 V)

Drive type	Frame size	Typical power loss ¹⁾		Air flow		Noise		IEC fuses		UL fuses			
		(W)	BTU/Hr	(m ³ /h)	CFM	(dBA)	(A)	Fuse type	(A)	Fuse type	(A)	Fuse type	
ACS380-04xx-02A4-1	R0	33	113	–*)	–	–	–	10	gG	32	gR	10	UL class T
ACS380-04xx-03A7-1	R0	49	167	–*)	–	–	–	10	gG	32	gR	10	UL class T
ACS380-04xx-04A8-1	R1	67	229	57	33	63	16	gG	40	gR	20	UL class T	
ACS380-04xx-06A9-1	R1	93	317	57	33	63	20	gG	50	gR	20	UL class T	
ACS380-04xx-07A8-1	R1	106	362	57	33	63	25	gG	63	gR	25	UL class T	
ACS380-04xx-09A8-1	R2	92	314	63	37	59	32	gG	63	gR	25	UL class T	
ACS380-04xx-12A2-1	R2	115	392	63	37	59	35	gG	63	gR	35	UL class T	

3-phase, $U_N = 230$ V (range 200 to 240 V)

ACS380-04xx-02A4-2	R1	39	133	57	33	63	6	gG	25	gR	6	UL class T
ACS380-04xx-03A7-2	R1	57	194	57	33	63	10	gG	32	gR	10	UL class T
ACS380-04xx-04A8-2	R1	72	246	57	33	63	10	gG	32	gR	10	UL class T
ACS380-04xx-06A9-2	R1	111	379	57	33	63	16	gG	40	gR	20	UL class T
ACS380-04xx-07A8-2	R1	105	358	57	33	63	16	gG	40	gR	20	UL class T
ACS380-04xx-09A8-2	R1	140	478	57	33	63	16	gG	40	gR	20	UL class T
ACS380-04xx-12A2-2	R2	149	508	63	37	59	25	gG	50	gR	25	UL class T
ACS380-04xx-17A5-2	R3	265	904	128	75	66	32	gG	63	gR	35	UL class T
ACS380-04xx-25A0-2	R3	398	1358	128	75	66	50	gG	80	gR	40	UL class T
ACS380-04xx-033A-2	R3	350	1194	128	75	66	63	gG	100	gR	60	UL class T
ACS380-04xx-048A-2	R4	561	1914	150	88	69	100	gG	160	gR	100	UL class T
ACS380-04xx-055A-2	R4	676	2307	150	88	69	100	gG	160	gR	100	UL class T

3-phase $U_N = 400$ V (range 380 to 480 V)

ACS380-04xx-01A8-4	R0	28	96	–	–	–	4	gG	25	gR	6	UL class T
ACS380-04xx-02A6-4	R1	44	150	57	33	63	6	gG	25	gR	6	UL class T
ACS380-04xx-03A3-4	R1	55	188	57	33	63	6	gG	25	gR	6	UL class T
ACS380-04xx-04A0-4	R1	62	212	57	33	63	10	gG	32	gR	10	UL class T
ACS380-04xx-05A6-4	R1	91	311	57	33	63	10	gG	32	gR	10	UL class T
ACS380-04xx-07A2-4	R1	100	341	57	33	63	16	gG	40	gR	20	UL class T
ACS380-04xx-09A4-4	R1	140	478	57	33	63	16	gG	40	gR	20	UL class T
ACS380-04xx-12A6-4	R2	165	563	63	37	59	25	gG	50	gR	25	UL class T
ACS380-04xx-17A0-4	R3	259	884	128	75	66	32	gG	63	gR	35	UL class T
ACS380-04xx-25A0-4	R3	390	1331	128	75	66	50	gG	80	gR	40	UL class T
ACS380-04xx-033A-4	R3	396	1351	128	75	66	63	gG	100	gR	60	UL class T
ACS380-04xx-038A-4	R4	497	1696	150	88	69	80	gG	125	gR	80	UL class T
ACS380-04xx-045A-4	R4	582	1986	150	88	69	100	gG	160	gR	100	UL class T
ACS380-04xx-050A-4	R4	672	2293	150	88	69	100	gG	160	gR	100	UL class T

¹⁾ Typical drive losses when it operates at 90% of the motor nominal frequency and 100% of the drive nominal output current.

Circuit breakers

1-phase $U_N = 230$ V (range 200 to 240 V)

Drive type	Frame size	ABB miniature circuit breaker	
		Type	(kA) ¹⁾
ACS380-04xx-02A4-1	R0	S 201P-B 10 NA	5
ACS380-04xx-03A7-1	R0	S 201P-B 10 NA	5
ACS380-04xx-04A8-1	R1	S 201P-B 16 NA	5
ACS380-04xx-06A9-1	R1	S 201P-B 20 NA	5
ACS380-04xx-07A8-1	R1	S 201P-B 25 NA	5
ACS380-04xx-09A8-1	R2	S 201P-B 25 NA	5
ACS380-04xx-12A2-1	R2	S 201P-B 32 NA	5

3-phase, $U_N = 230$ V (range 200 to 240 V)

ACS380-04xx-02A4-2	R1	S 203P-Z 6 NA	5
ACS380-04xx-03A7-2	R1	S 203P-Z 8 NA	5
ACS380-04xx-04A8-2	R1	S 203P-Z 10 NA	5
ACS380-04xx-06A9-2	R1	S 203P-Z 16 NA	5
ACS380-04xx-07A8-2	R1	S 203P-Z 16 NA	5
ACS380-04xx-09A8-2	R1	S 203P-Z 25 NA	5
ACS380-04xx-12A2-2	R2	S 203P-Z 25 NA	5
ACS380-04xx-17A5-2	R3	S 203P-Z 32 NA	5
ACS380-04xx-25A0-2	R3	S 203P-Z 50 NA	5
ACS380-04xx-033A-2	R3	S 203P-Z 63 NA	5
ACS380-04xx-048A-2	R4	–	–
ACS380-04xx-055A-2	R4	–	–

3-phase $U_N = 380...480$ V (380, 400, 415, 440, 460, 480 V)

ACS380-04xx-01A8-4	R0	S 203P-B 4	5
ACS380-04xx-02A6-4	R1	S 203P-B 6	5
ACS380-04xx-03A3-4	R1	S 203P-B 6	5
ACS380-04xx-04A0-4	R1	S 203P-B 8	5
ACS380-04xx-05A6-4	R1	S 203P-B 10	5
ACS380-04xx-07A2-4	R1	S 203P-B 16	5
ACS380-04xx-09A4-4	R1	S 203P-B 16	5
ACS380-04xx-12A6-4	R2	S 203P-B 25	5
ACS380-04xx-17A0-4	R3	S 203P-B 32	5
ACS380-04xx-25A0-4	R3	S 203P-B 50	5
ACS380-04xx-033A-4	R3	S 203P-B 63	5
ACS380-04xx-038A-4	R4	S 803S-B 80	5
ACS380-04xx-045A-4	R4	S 803-B 100	5
ACS380-04xx-050A-4	R4	S 803-B 100	5

¹⁾ Maximum permitted rated conditional short-circuit current (IEC 61800-5-1) of the electrical power network.



ACS380 DRIVES ARE COMPATIBLE with the extensive ABB product offering



Programmable Logic Controllers PLCs

The AC500, AC500-eCo, AC500-S and AC500-XC scalable PLC ranges provide solutions for small, medium and high-end applications. Our AC500 PLC platform offers different performance levels and is the ideal choice for high availability, extreme environments, condition monitoring, motion control or safety solutions, and applications where the highest level of security is mandatory.



AC motors

ABB's low-voltage AC motors are designed to save energy, reduce operating costs and minimize unscheduled downtime. General performance motors ensure convenience, while process performance motors provide a broad set of motors for the process industries and heavy-duty applications.



Control panels

CP600-eCo, CP600 and CP600-Pro control panels offer a wide range of features and functionalities for maximum operability. ABB control panels are distinguished by their robustness and easy usability, providing all the relevant information from production plants and machines at a single touch. Also, includes the CCE protocol – ABB's internal drive communication protocol – for seamless integration with ABB drives, enabling efficient parameter read/write access and real-time monitoring and visualization.



All-compatible drives portfolio

The all-compatible drives share the same architecture: software platform; tools; user interfaces; and options. However, there is an optimal drive, from the smallest water pump to the biggest cement kiln, and everything in between.



Safety products

ABB safety products help machine builders create production-friendly and safe work environments for operators. We deliver machine safety solutions for single machines or entire production lines. Our long experience of helping customers making solutions for demanding environments has made us experts in combining production demands with safety demands for production-friendly solutions.

BEST-IN-CLASS PERFORMANCE, ENERGY EFFICIENCY AND RELIABILITY WITH ABB MOTOR AND DRIVE PACKAGE

High Dynamic Performance (HDP) motors with ACS380 drives

ABB's HDP motors have a very high power density, which means that they provide more power to the machine applications than conventional machine motors. ABB's HDP motors are the optimal solution for high-torque machine applications such as extruders, cranes, test benches, etc.

ABB HDP motors are always used with a drive. To make full use of ABB's VSDs – including flexibility to optimize processes and control, reliability to reduce downtime, and efficiency to reduce energy use and carbon emissions – the motor's technology solution must be up to the challenge. ABB's HDP motors are designed to enable fast motion control and high maneuvering precision due to their low inertia and high overload capacity.

Induction motors and ACS380: a reliable combination

Induction motors are used throughout industry in applications that demand robust and high-enclosure motor and drive solutions. ACS380 drives fit perfectly with this type of motor by providing comprehensive functionality, yet simple operation. The drives are ideal for environments that require a high degree of protection and a small footprint. Our motors and drives provide the perfect foundation for energy efficiency while delivering capabilities such as exceeding the nominal motor speed when maximum power is needed.

Our low-voltage motors for explosive atmospheres and low-voltage industrial drives have been tested and certified to verify that when correctly dimensioned, they are safe to use in explosive atmospheres. ABB drives can also be used with non-ABB Ex motors with ATEX-certified thermistor protection. If this protection is not used, the motor and drive combination must be either type-tested or combined-tested for potentially explosive atmospheres by the customer, motor manufacturer or a third party. It is also important to verify that the motor can be used with ABB variable speed drives.

Permanent magnet motors and ACS380: smooth operation

Permanent magnet technology is used for improved motor characteristics in terms of energy efficiency and compactness. This technology is particularly suitable for low-speed control applications, as in some cases it eliminates the need to use gearboxes. The actual characteristics of different permanent magnet motors can vary considerably. Even without speed or rotor position sensors, ACS380 drives can control most types of permanent magnet motors.

IE5 Synchronous reluctance motors and ACS380: optimized energy efficiency

Combining ACS380's control technology with our Synchronous reluctance (SynRM) motors provides an IE5 motor and drive package that ensures high energy efficiency, reduces motor temperatures and provides a significant reduction in motor noise. A lower temperature results in better motor reliability and longer motor life.

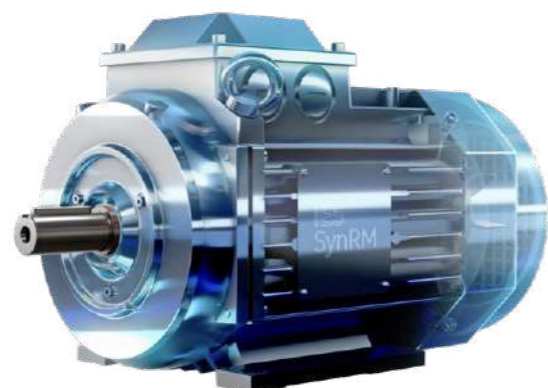

SYNCHRONOUS RELUCTANCE MOTORS

Ultimate efficiency and reliability to optimize your cost of ownership



Traditional induction motor



IE5 SynRM motor

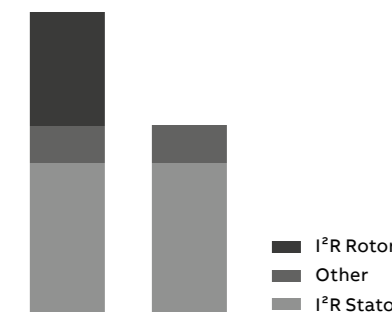

Losses IM vs. SynRM

Innovation inside

The idea is simple. Take a proven conventional stator technology and an innovative rotor design. Then combine them with an ABB machinery drive loaded with software with versatile features. Finally, optimize the whole package for applications such as compressors, conveyors, pumps, extruders, fans, and many other variable and constant torque applications.

Magnet-free design

Synchronous reluctance technology combines the performance of a permanent magnet motor with the simplicity and service-friendliness of an induction motor. The new rotor has neither magnets nor windings and suffers virtually no power losses. And because there are no magnetic forces in the rotor, maintenance is as straightforward as with induction motors.

Superior reliability to minimize the cost of not running

International Efficiency class IE5 Synchronous reluctance motors (SynRM) have very low winding temperatures, which increases the reliability and lifetime of the winding. More importantly, a cool synchronous reluctance rotor means significantly lower bearing temperatures – an important factor because bearing failures cause about 70 percent of unplanned motor outages.

Perfect for retrofits

The SynRM package is a perfect solution for motor retrofits. The IE5 SynRM is the same size as an IE3 induction motor, eliminating the need for mechanical modifications. Meanwhile, the increased efficiency will reduce the payback time of the investment.

Full motor control, down to zero speed

Many processes require accurate speed control. SynRM always runs at the reference speed with practically no error, without an encoder. Even the best slip compensation systems in an induction motor inverter will never match the precision of SynRM. Sometimes your application may require you to run your motor at slow speeds. If you are using SynRM, and your drive cannot provide the necessary torque, it may trip. ABB drives provide full control and torque down to zero speed, even without speed sensors.

For all applications

This is important if you are planning to use the motor with applications other than quadratic torque applications like pumps and fans. Our drives provide full SynRM motor control for constant torque applications such as extruders, conveyors and wire drawing machines.

Certified safety with IE5 SynRM Increased safety motors and Drives in hazardous areas

ABB is the first manufacturer in the world to offer the combination of IE5 ultra-premium efficiency and Increased safety. ABB IE5 SynRM increased safety motors for Zones 1 and 2 are fully tested and certified for explosive atmospheres with drives. Increased Safety SynRM motors provide all the benefits of SynRM motors such as ultra-premium efficiency, higher reliability and reduced maintenance.

SynRM technology	Benefit
Higher efficiency IE5	Lowest energy consumption
No rare earth metals	Environmental sustainability
Magnet-free rotor	Easy service
Lower winding and bearing temperatures	Longer lifetime, extended service intervals
Better controllability	Accurate speed and torque control
Lower noise level	Better working and living environment
Same size with IE3	Perfect for retrofits

DIGITAL CONNECTIVITY FOR DRIVES AND MOTORS

+ ABB Ability™ Mobile Connect for drives

Easy access to remote support

ABB Ability™ Mobile Connect for drives is a platform for remote drive support consisting of the Mobile Connect web portal and the Drivetune mobile app.

The platform allows ABB service partners to provide remote commissioning and troubleshooting support for personnel on-site without any complex connectivity infrastructure. Chats, sharing images and backups, viewing parameters online and sending support packages are all possible,

making your technical support process quick and efficient.

All that is needed is the Bluetooth control panel and a mobile device.

The platform is available for ABB partners and OEMs under a renewable subscription-based agreement.

[ABB Ability™ Mobile Connect for drives support portal](#)

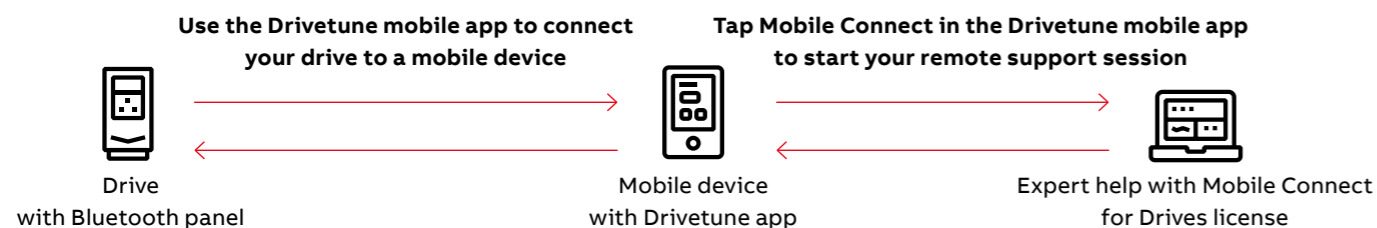

+ Drivetune mobile app for managing drives via an intuitive interface

Drivetune mobile app is a powerful tool for performing basic drive startup and troubleshooting tasks. It is possible to connect with drives and access data available in the Internet at the same time. The wireless Bluetooth

connectivity means that users won't need to enter hazardous or difficult-to-reach work areas to access information necessary to help them commission and tune the drive.



- Startup, commission and tune your drive and application with full parameter access
- Optimize performance via drive troubleshooting features
- Create and share backups and support packages
- Keep track of drives installed base

Download Drivetune mobile app



+ Drivetune mobile app

Motor QR code reader for quick and reliable motor parameter setting with ABB Drive-Motor package

Drivetune mobile app with motor QR code reader quickly and easily transfers ABB motor* data to drive parameters.



Faster and easier commissioning

- Quick and reliable motor parameter setup
- Scan the QR code or enter the motor serial number to get the data for parameters
- Less manual work and reduced risk of error when commissioning motors
- Drivetune helps to filter motor configurations

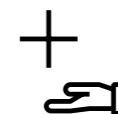

Easy to use

- Same motor QR code for ABB Access and Drivetune
- Share motor nameplate file between users/devices
- Add descriptive name and comments to motor nameplate file

ABB motors and drives are designed to complement each other, allowing you to optimize your machine speed and reduce energy consumption.

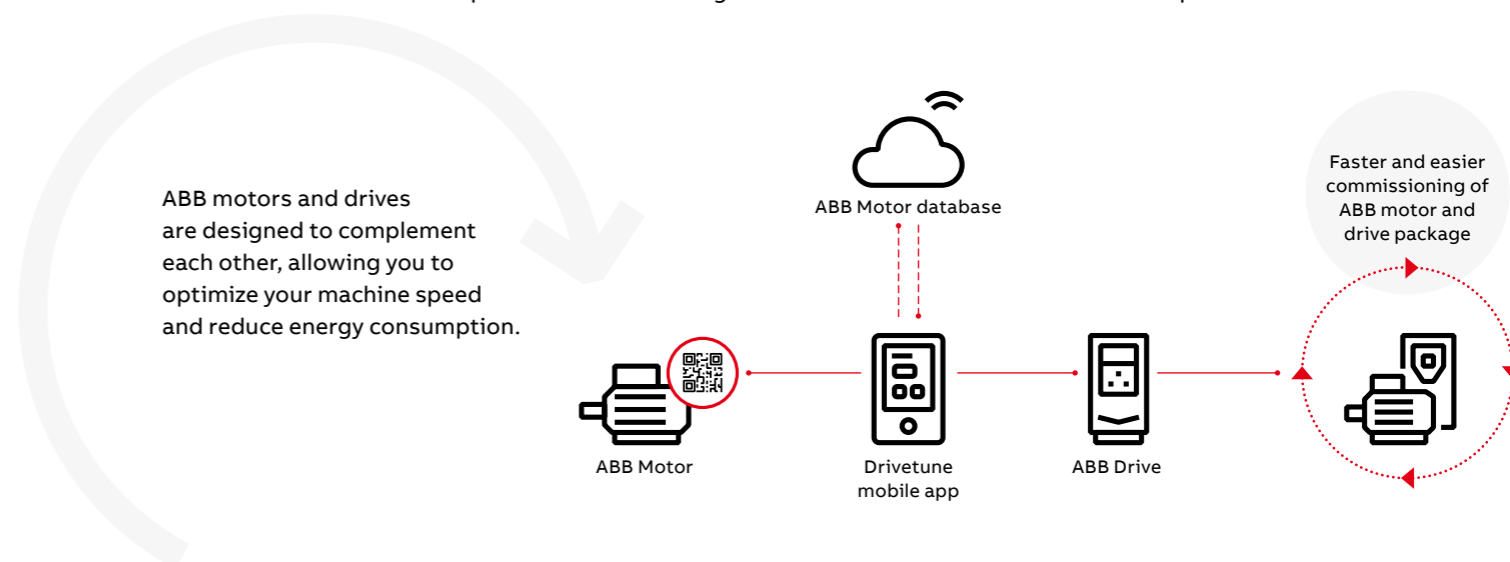

Download free from the [Apple App Store](#) or [Google Play](#).



* Drivetune does not currently support all ABB motors. We are working to expand the range of supported motors. If you receive a message saying 'data not available' when scanning a QR code, you will need to enter the data manually.

More information about the Drivetune app can be found on the [ABB website](#).

DRIVE COMPOSER 3 WITH ACS380

New generation of integration between drives and user tools



Drive Composer 3 is the latest version of our easy-to-use, reliable, and secure tool for faster commissioning, monitoring, and troubleshooting ABB all-compatible drives. The tool can also be used for optimizing drive performance.

01

More efficient than ever

- Fast, reliable connectivity options
- Quick, effortless commissioning
- Advanced features for power users

02

Easy to use

- Backward compatible and future-proof
- Easy to get started
- Faster commissioning and reduced risk

03

Reliable and secure

- Reliable remote troubleshooting
- Secure by design

Versatile PC connectivity

- Connectivity with ACS380 and other selected drives
 - USB-C connectivity on drive
 - Ethernet connectivity for tool network and fieldbus communication
- Connectivity with other drive models
 - USB connection via Assistant Control Panel (ACP)
 - Ethernet connectivity via Ethernet fieldbus adapter modules
- ACS380 supports
 - The new Drive Composer 3 as well as earlier 2.x versions
- Supported operating systems
 - Windows 10 and 11

01



02



03



Find out more and
download the tool:



ABB MOTION SERVICES

ABB Motion Services helps customers around the globe by maximizing uptime, extending product life cycle, and enhancing the performance and energy efficiency of electrical motion solutions. We enable innovation and success through digitalization by securely connecting and monitoring our customers' motors and drives, increasing operational uptime, and improving efficiency. We make the difference for our customers and partners every day by keeping their operations running profitably, safely and reliably.

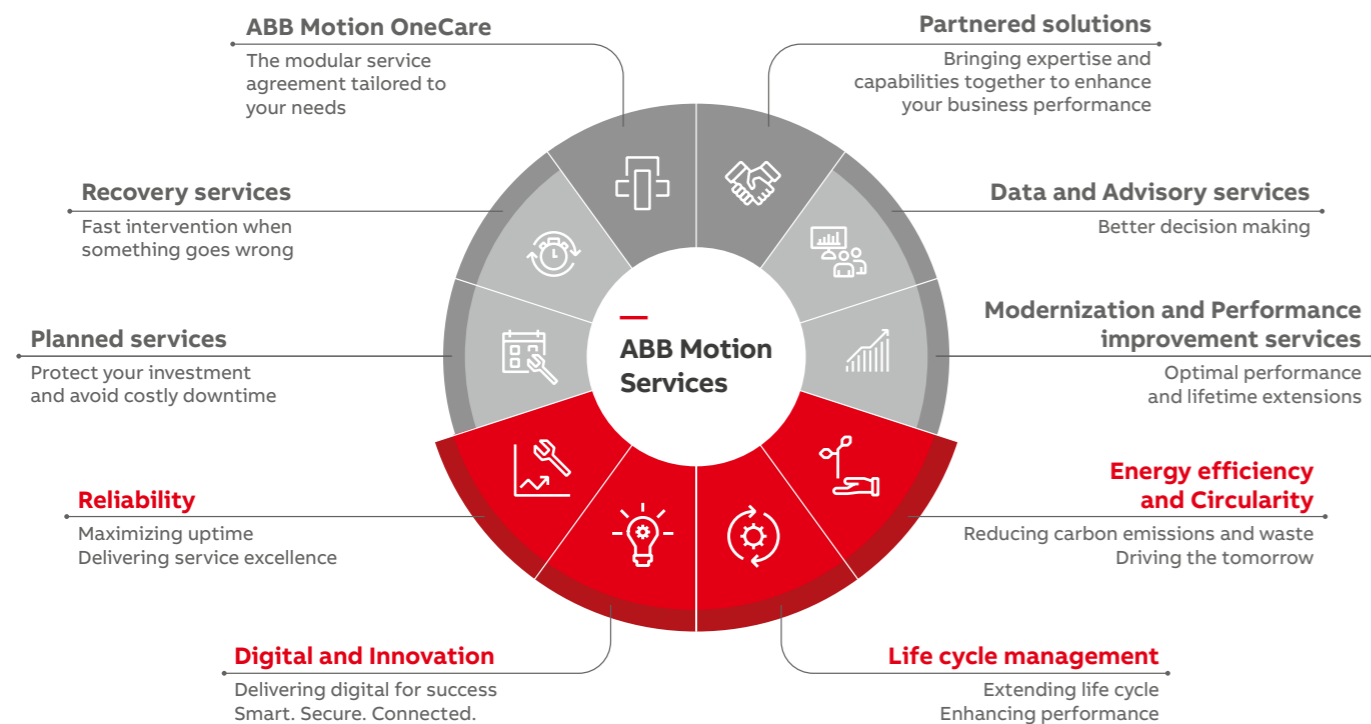

OUR EXPERTISE
YOUR ADVANTAGE

A LIFETIME OF PEAK PERFORMANCE

You're in control of every life-cycle phase of your drives. At the heart of drive services is a four-phase product life-cycle management model. This model defines the services recommended and available throughout drives lifespan.

Now it's easy for you to see the exact service and maintenance available for your drives.

ABB drives life-cycle phases explained:

	Active	Classic	Limited	Obsolete
	Full range of life-cycle services and support	Limited range of life-cycle services and support	Replacement and end-of-life services	
Product	Product is in active sales and manufacturing phase	Serial production has ceased. Product may be available for plant extensions, as a spare or for installed base renewal	Product is no longer available	Product is no longer available
Services	Full range of life cycle services is available	Full range of life-cycle services is available. Product enhancements may be available through modernizations	Limited range of life-cycle services is available. Spare parts availability is limited to available stock	Replacement and end-of-life services are available

Keeping you informed

We notify you every step of the way using life-cycle status statements and announcements.

The benefit for you is clear information about the status of your drives and the exact services available. It helps you plan the preferred service actions ahead of time and make sure that continuous support is always available.

Step 1

Life-cycle Status Announcement

Provides early information about the upcoming life-cycle phase change and how it affects the availability of services.

Step 2

Life-cycle Status Statement

Provides information about the drive's current life-cycle status, the availability of product and services, the life-cycle plan, and recommended actions.

Additional information

We reserve the right to make technical changes or modify the contents of this document without prior notice. With regard to purchase orders, the agreed particulars shall prevail. ABB does not accept any responsibility whatsoever for potential errors or possible lack of information in this document.

We reserve all rights in this document and in the subject matter and illustrations contained therein. Any reproduction, disclosure to third parties or utilization of its contents – in whole or in parts – is forbidden without prior written consent of ABB.